

Didactic concept GUNT DigiSkills 1

The digitisation of
the world of work –
new requirements
for education

Designing training
in metalworking
professions

Our leaning projects help you
to implement the new require-
ments

Didactic concept for a fundamental learning project

Engineering drawing – Technical communication **digital**

Planning training elements and teaching courses



Table of contents

1	Module 1 Geometric models	04
1.1	Development of spatial imagination	04
1.2	Three-view display	05
1.3	The engineering drawing	05
1.4	Geometric base bodies	06
1.5	Selected exercises	06
1.6	The GUNT Media Center	07
2	Module 2 Functional models	08
2.1	Presentation of functional models	08
2.2	Engineering drawing	09
2.3	Measurement exercises	09
2.4	Digital tools and methods	09
2.5	Assembly and assembly planning	10
2.6	Identifying and describing functions	11
2.7	The storage system	11
2.8	Example exercise	12
3	Module 3 Geometrical Product Specifications	14
3.1	ISO GPS: introduction	14
3.2	MT 121 Assembly exercise: mitre gear	15
3.3	Example exercise	16
4	Learning contents	18
5	What students and teachers say	20
6	Product list and tender specifications	22
7	Summary – Outlook	23

Foreword

More than any other group, the industrial metal-working and electrical professions are in the spotlight when it comes to **digitalisation** and **Industry 4.0**. The new profession profile Digitalisation of Work – binding for all German establishments – requires the concrete implementation of the fields of competence and training content relevant to Industry 4.0. Conventional and innovative techniques coexist and must both be mastered. As a **vertical integration of learning content**, the new profession profile: Digitalisation of Work, is taught over the entire training period in the training company and in the vocational school.

GUNT can help you with these complex vocational educational tasks. Our practical, work process-oriented learning projects, which are perfectly suited to developing digital skills, are available to you in the form of the **GUNT DigiSkills product line**.

There is no need for expensive investments in com-

plex networked model systems for manufacturing and robotics in your laboratories and workshops. With our GUNT DigiSkills concepts, we show you that training can be easier, cheaper and more tangible. The federal/state funding from the Digitalpakt can be used without restriction if you want to procure GUNT DigiSkills learning projects in your establishment.

The motivation and learning progress of your students/trainees will reward you as a trainer or as a teacher if you use GUNT DigiSkills learning projects.

Notes:

This document does not make any scientific claims. It is designed to be practical, as a direct stimulus for modern teaching and process-oriented education. The digitalisation goals apply everywhere: in the training organisation and in the vocational school and in vocational qualification.

The author's aim is to generate dialogue with you.

The GUNT DigiSkills 1 learning project

This learning project provides an introduction to engineering drawing, and familiarises students with the many variants of technical communication. The fundamental basis for spatial imagination is formed by our **Geometric models** from **module 1**, with different shapes: TZ 100, TZ 110, TZ 120, TZ 130 and TZ 140. These drawing models include a digital learning environment for you and your trainees in our **GUNT Media Center**. Here you will find extensive materials to allow you to branch out to topics such as materials, surfaces, dimensions, tolerances, and many more.

The **Functional models**: TZ 200.01, TZ 200.07 and TZ 300 from **module 2** help you to take the first steps towards technological functions and interrelationships. These GUNT products are also simple, fundamental and real. Digitally supported by access to extensive, digital teaching material in the GUNT Media Center.

Our MT 121 Assembly exercise: mitre gear from **module 3** is available to demonstrate the application of the **Geometrical Product Specifications (GPS)**.

End devices such as notebooks, tablets, smartphones or PCs are supported. All you need is a stable internet connection and a browser. You do not have to buy any licences.

These simple models can accompany you through an entire training course. The range of learning objectives and the level of difficulty range from "simple to complex". By using real-world models, you move into modern digital technologies: CAD design, 3D printing, 3D scanning.

The exercises last 45 or 90 minutes and are perfectly designed for working in pairs. They can be carried out in simple classrooms.



About the author

Rudolf Heckmann is Managing Director at G.U.N.T. Gerätebau GmbH, and is responsible for programme development and didactic concepts. Education: Mechanical engineering and physics, 10 years teaching experience in the vocational/technical sector. Extensive scientific work on engineering pedagogy and subject didactics. Founder of the international GUNT Technical Academy.

GUNT DigiSkills learning projects

	1 Engineering drawing – Technical communication
	2 Dimensional metrology
	3 Preventive maintenance
	4 Energy efficiency in compressed air systems
	5 Robotics and automation

Module 1
Geometric models with base body shapes

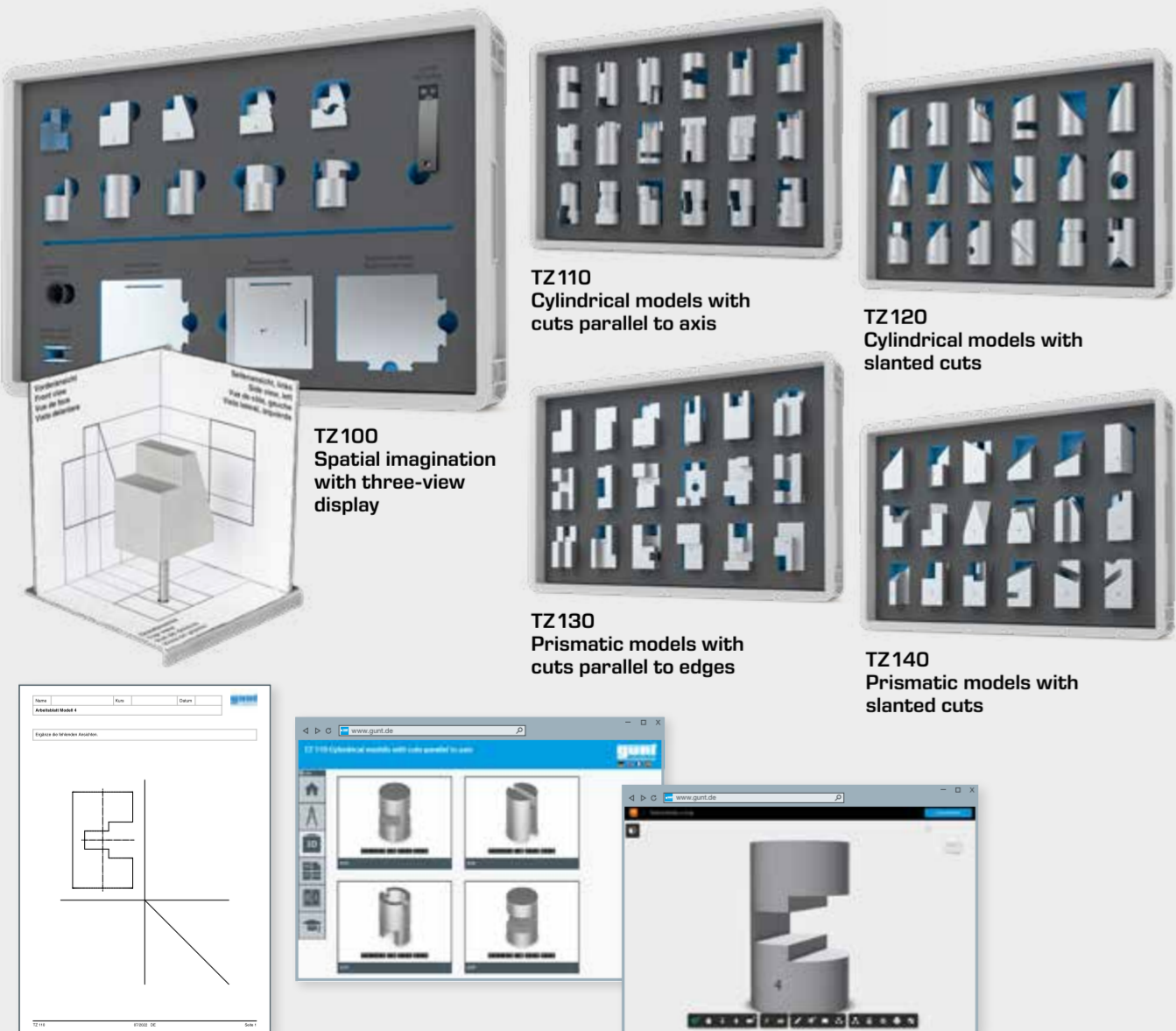

The GUNT Media Center offers accompanying digital documents for the individual modules.

Module 2
Functional models



Module 3
Developing the fundamentals of Geometrical Product Specifications (GPS)



1 | Module 1 Geometric models with base body shapes

The first step is to develop spatial imagination. A spatial image is developed from two-dimensional views of a model or component.

And vice versa: a real, physical model is represented by different two-dimensional views. This intellectual process is a mental skill that needs to be developed.

Using the **multiview projection**, it is possible to explain two-dimensional views in an understandable way. Only people who can understand the projection are able to produce an engineering drawing of a component.

With module 1, GUNT offers five sets of models with **Geometric models**. To start with, TZ 100 establishes and trains the spatial imagination. TZ 110 to TZ 140 contain models with different shapes, used to practise the representation in three views.

1.1 | Development of spatial imagination

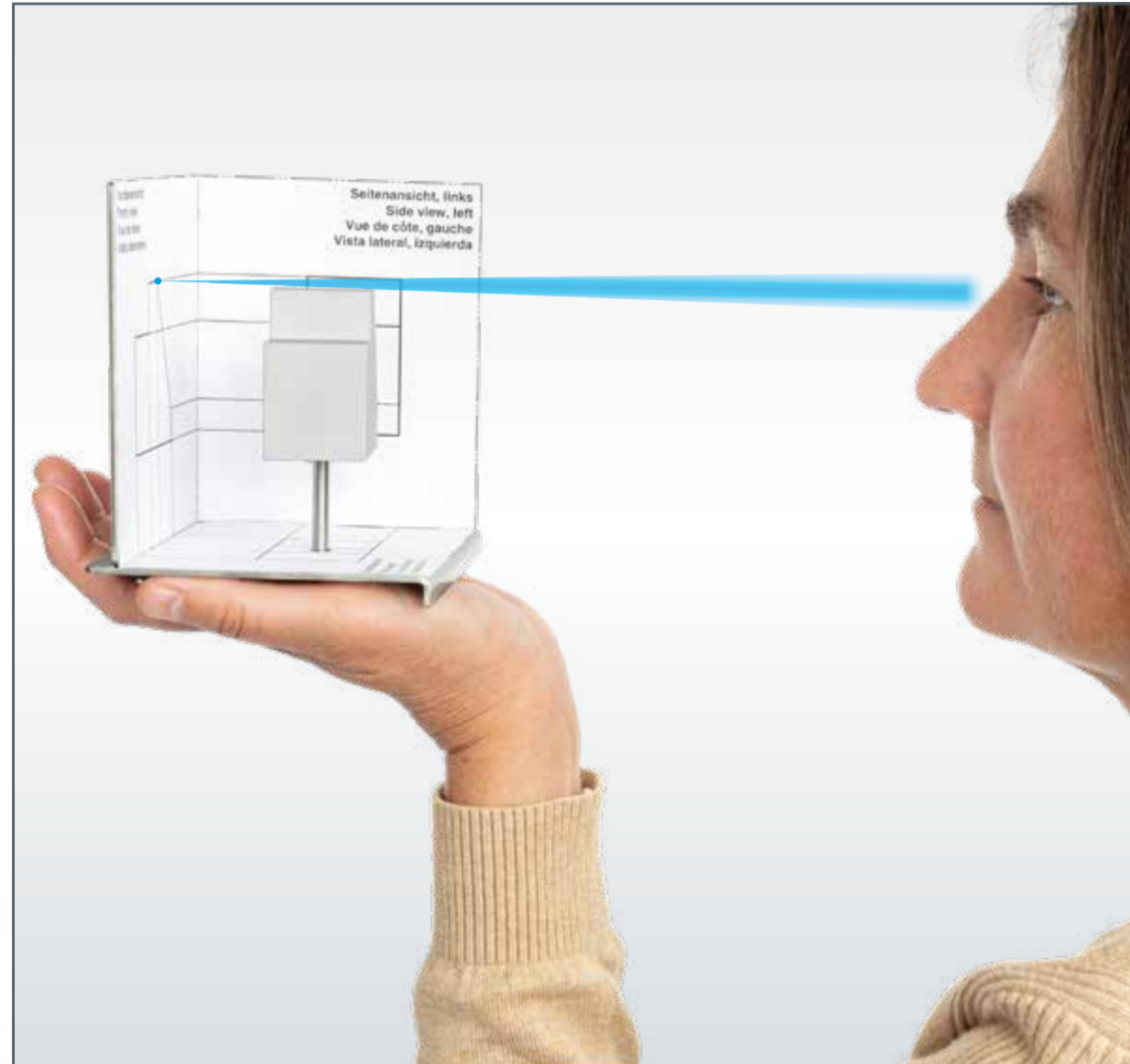

"Learning to walk" in engineering drawing. In the **first step**, the room corner with an inserted drawing and the real model shows, in an understandable way, what the three views look like. Looking at the model from the correct angle trains the spatial imagination skill.

TZ 100 Spatial imagination with three-view display

- set of models for developing spatial imagination
- fundamentals of the three-view display
- ten simple prismatic and cylindrical models with different degrees of difficulty
- each model can be placed in the room corner
- a transparent model supports the understanding of invisible edges
- precisely manufactured models, suitable for measurement exercises
- access to the GUNT Media Center with digital materials such as drawings in STP, DXF, PDF formats

Objectives:

Step-by-step development of spatial imagination by looking at the different models

- 1 locate lines and points on the drawing and on the model
- 2 locate hidden edges on the transparent model
- 3 understand projection directions for front view, side view and plan view
- 4 understand the "folding mechanism": from front view to side view and plan view

The room corner of TZ 100 with an inserted drawing and a model

The three-view display of a model, on paper, can be cut and folded so that it can be inserted precisely into the room corner. Then the real model is placed on a prong. This allows the students/trainees to look at, compare and understand the parallel projection. Everything is up-close and direct – and tangible.

Models in TZ 100



Four prismatic models made of aluminium and one made of acrylic.

Five cylindrical models made of aluminium. Surfaces, grooves, breakthroughs are within the outer contour of the cylinder. Often difficult to understand, very easy to learn with these models.

1.2 | Three-view display



Detailed instructions, as well as exercises and solutions can be found in the GUNT Media Center

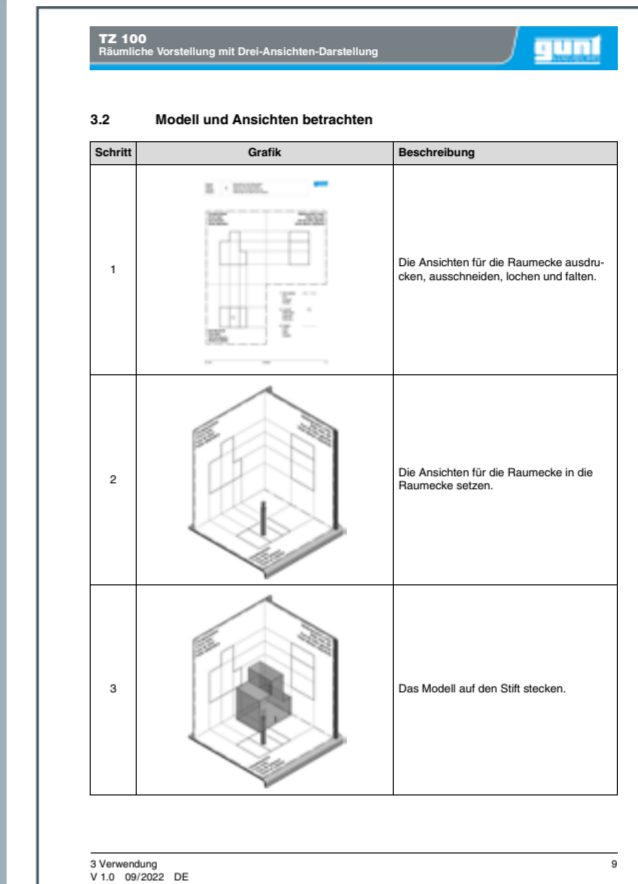

A page from the manual

The **second step** is to draw the models in the **three-view display**. The easiest way to draw or display in three views is to draw guide lines.

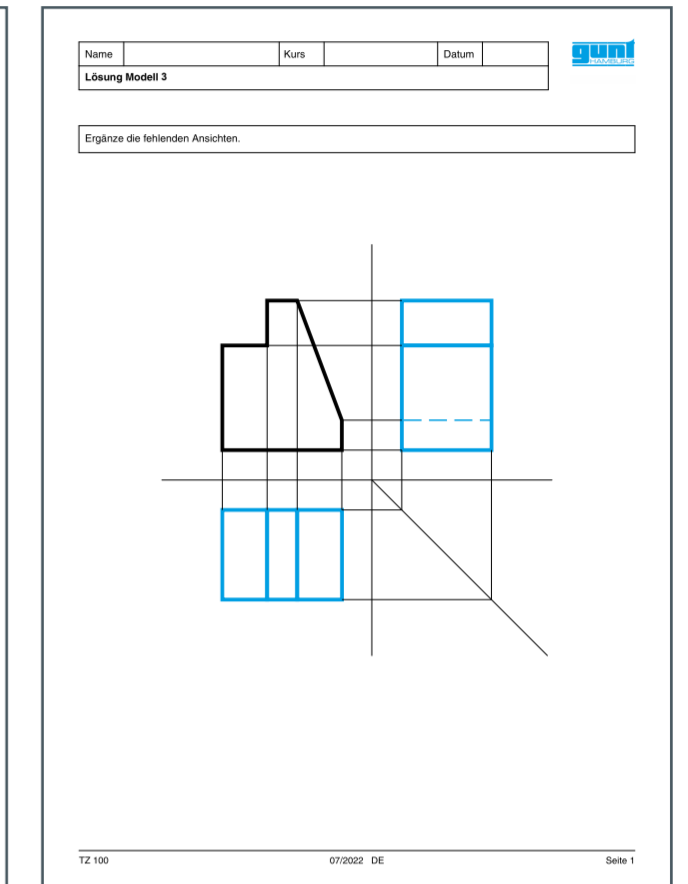

Solution sheet: Drawing the three views with guide lines

1.3 | The engineering drawing

In the **final step**, the guide lines are removed and an **engineering drawing** with complete dimensions and title block is created from the three-view display.

Transferring the dimensions from the original body can be designed as a measuring exercise.

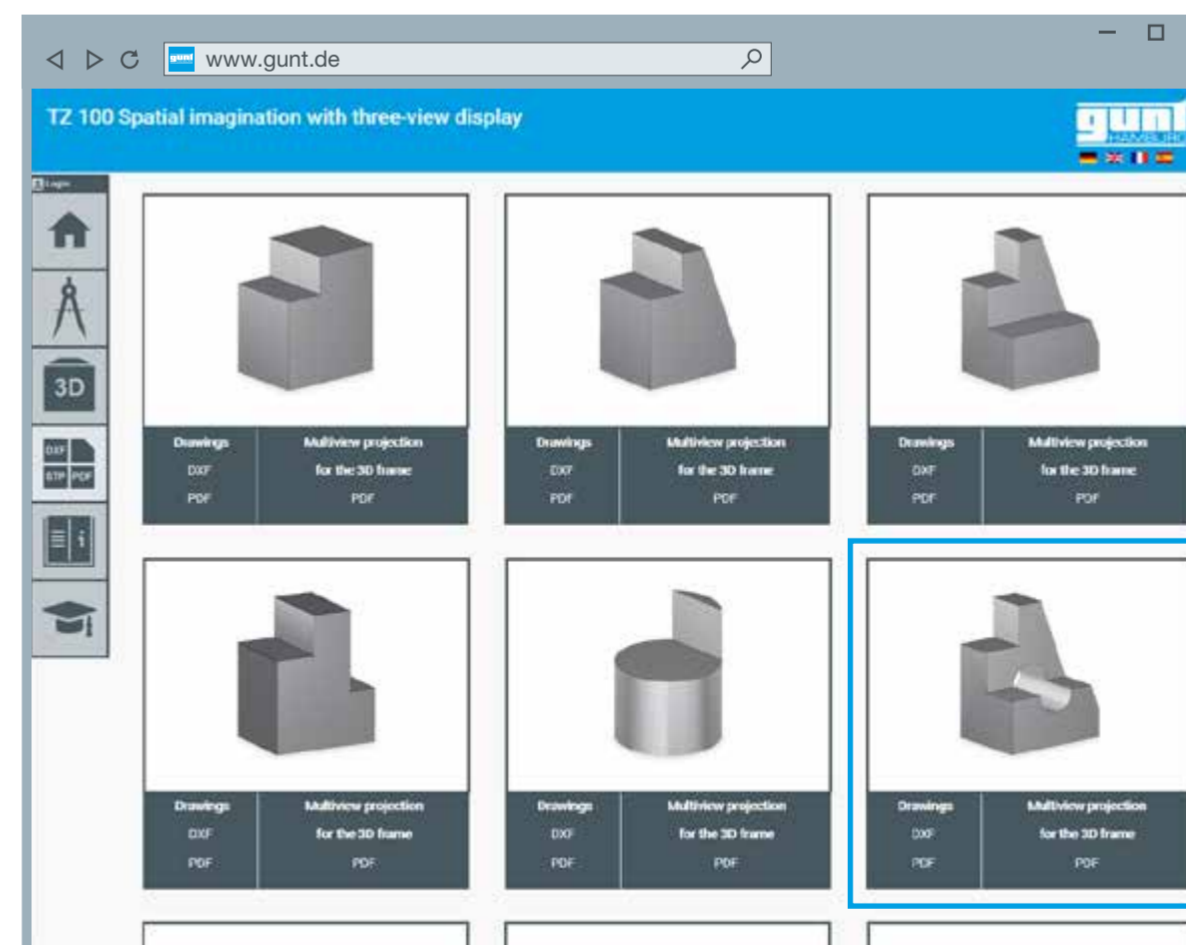

The GUNT Media Center has all models in STP format and all production drawings in DXF and PDF formats

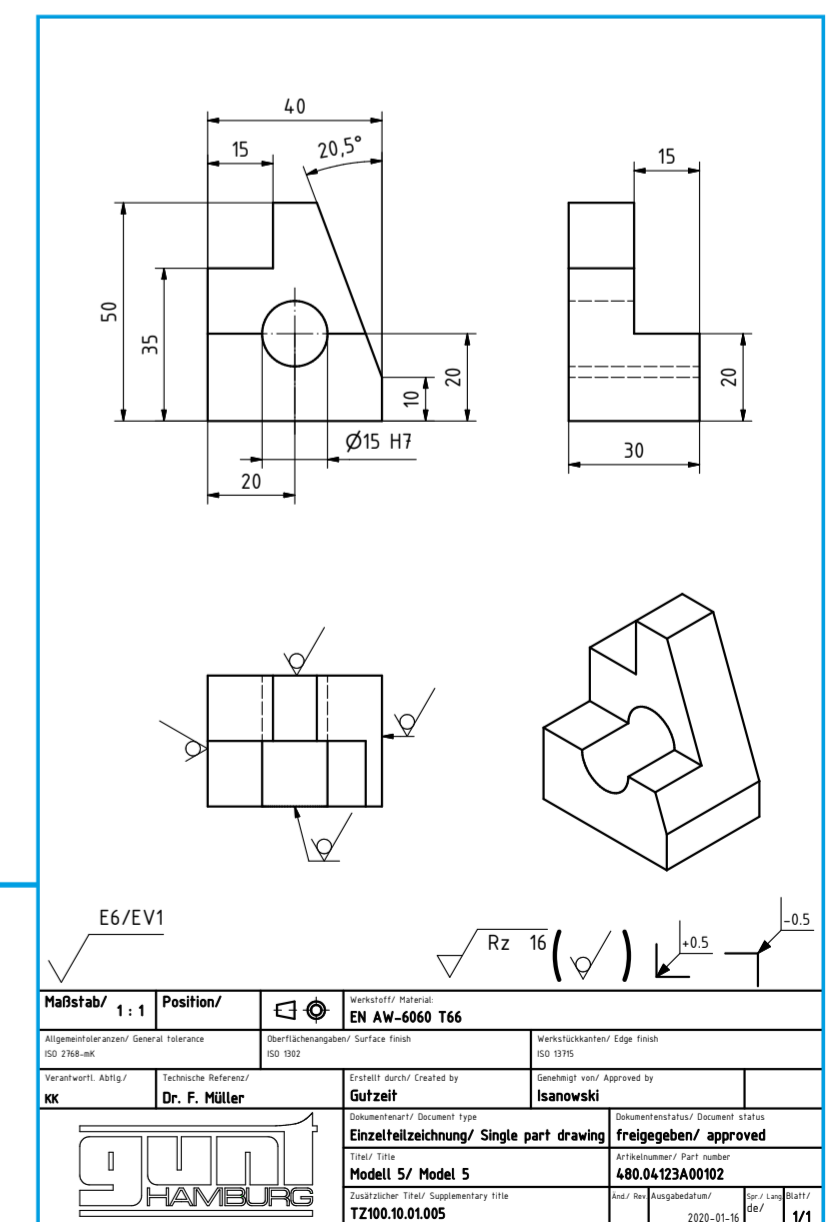

1 | Module 1 Geometric models with base body shapes

1.4 | Geometric base bodies as drawing models

Developing spatial imagination skills also trains a cognitive area that is important for technical competence: the intellectual transfer capacity to convert two-dimensional presentations in engineering drawings into a vivid, mentally generated 3D model and vice versa.

GUNT offers large models for this purpose, precision manufactured from metallic materials to "hold in your hand". To be viewed from all sides and from all directions.



- TZ110** contains cylindrical models with cut-outs **parallel** to the spatial axes
- TZ120** contains cylindrical models with cut-outs **parallel and oblique** to the spatial axes
- TZ130** contains prismatic models with cut-outs **parallel** to the spatial axes
- TZ140** contains prismatic models with cut-outs **parallel and oblique** to the spatial axes

1.5 | Example presentation of selected exercises

- Task:**
- 1 draw the missing views, use guide lines
 - 2 for advanced students: check the dimensions on the model or using the measuring tools in the STP model and transfer the dimensions to the drawing
- Additional task:**
- 3 create a complete engineering drawing based on a given view and the original model or the STP model in the GUNT Media Center
 - 4 edit the title block and add the surface details

The complete production drawing is available in the GUNT Media Center

1.6 | Using the GUNT Media Center for the exercises

- 1.** Everything about engineering drawing
The complete DigiSkills 1 learning project
- 2.** First select the TZ 110 set of models in the GUNT Media Center. Then press the **3D** button to go to the 3D models, select the desired model and open the STP file.
- 3.** Opening the **STP** file displays a digital 3D model. The **Viewer Tool** offers a selection of tools: rotate, pan, zoom, mark, measure, cut, explode model.
- 4.** The **Measure** tool can be used to find the dimensions of the model.
- 5.** The buttons take you to the **Drawings** in DXF and PDF format and to the **Worksheets** with tasks and solutions. Access to solutions is password protected.

Learning content – competence modules, summarised for module 1

Traditional learning content is worked on in a digital – and of course inclusive – environment. Switch back and forth between "real" and "virtual". We present learning contents separately for the sake of didactic clarity.

Development of digital skills	Traditional, technical content
<ul style="list-style-type: none"> ■ intensive use of digital media and tools, e.g. use of the GUNT Media Center ■ familiarisation with STP, DXF, PDF file formats ■ access 3D view from an STP file ■ use comprehensive possibilities of the A360 viewer tool: zoom, rotate, move, cut, measure ■ using mobile devices: smartphone, tablet 	<ul style="list-style-type: none"> ■ systematic development of spatial imagination ■ making the transformation process comprehensible and practising it: from two-dimensional drawing with three views to the spatial imagination – and vice versa ■ transforming a real geometric model into a three-view display ■ seeing and understanding special features, such as edges and lines of obliquely cut cylinders ■ sketching exercises: spatial image and technical representation ■ simple measuring exercises, transferring dimensions to the engineering drawing

2 | Module 2 Functional models

We want to develop spatial thinking with our geometric models from module 1. This demanding cognitive process is fostered and anchored through the use of real and virtual media.

The exercises and media offered are ideal for consolidating the basic principles of engineering drawing and especially the three-view display.

Our **Functional models** are used to expand on the basic principles of engineering drawing through technical applications and references.

Objectives

- creation of engineering drawings for real components
- consolidation of the three-view display through exercises
- measuring exercises on real components
- planning and carrying out the assembly
- recognising and describing simple functions from the field of **sheet metal fabrication**

2.1 | Presentation of functional models

The functional models are small "machines" or mechanisms:

- lever shear
- lever press
- bending press

Each model has its own, simple functions. All three mechanisms together show the production of a simple fastening clamp with the steps of **cutting, punching and bending**.

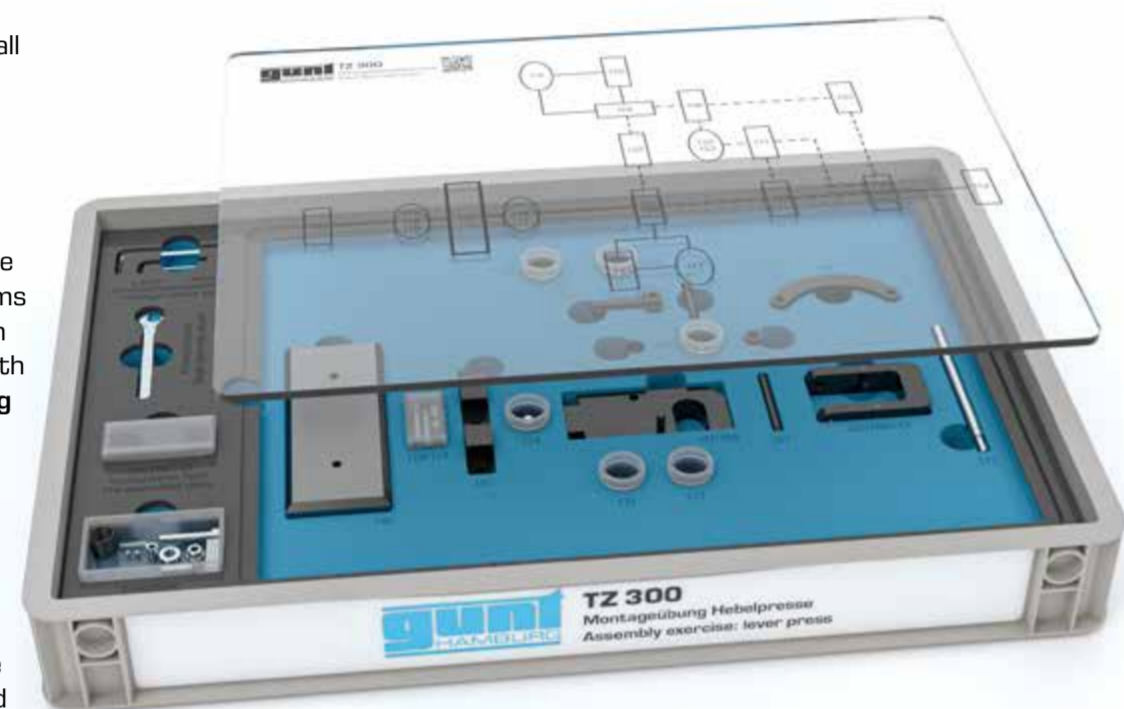

Assembly kit for the TZ 300 lever press, transparent cover plate with structural grid

- functional mechanisms as an assembly kit
- components stored as a recognisable assembly structure
- transparent plate represents structural grid with indications of the assembly process
- assembly relationships such as fixed or movable connection, standard part or production part are easily recognisable
- spare parts and simple tools available
- production parts with surface protection for a high-quality appearance

Production of a fastening clamp



Cutting sheet metal with the **lever shear** from TZ 200.07



Punching holes with the **lever press** from TZ 300



Forming the workpiece with the **bending press** from TZ 200.01

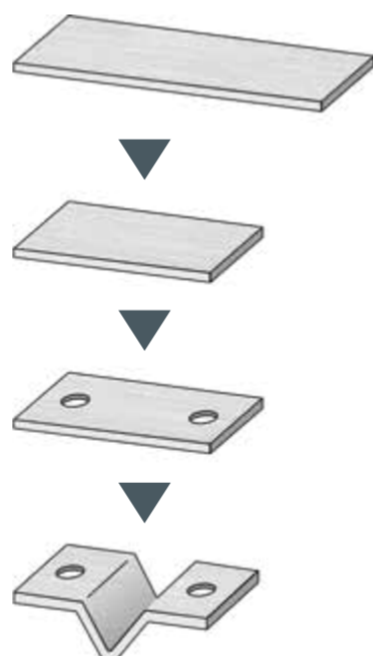

Access to the GUNT Media Center provides you with comprehensive digital materials and tools to create flexible and modern lessons.

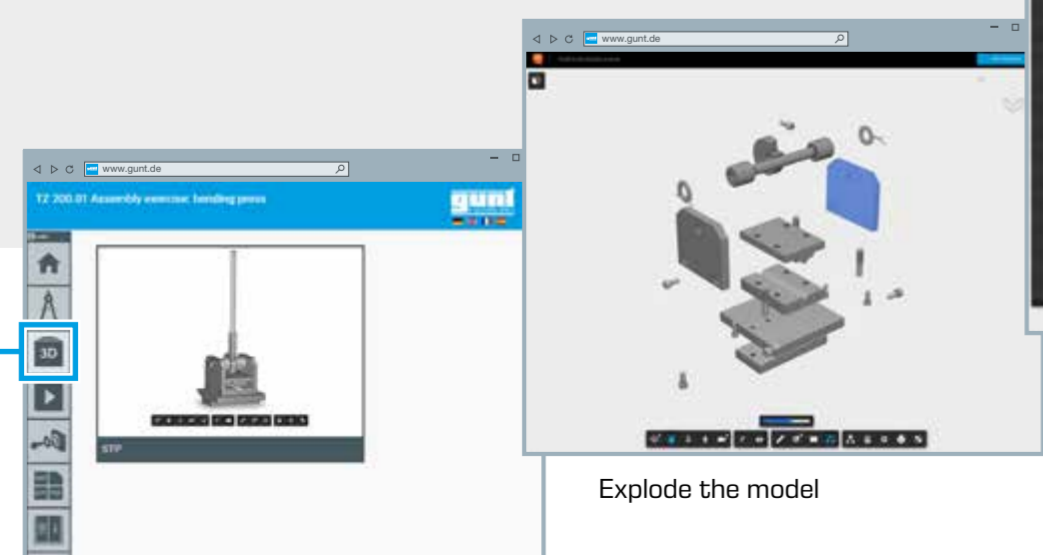

Open the 3D model

Explode the model

Isolate individual components using the model browser

2.2 | Engineering drawing

The combination of media: a real functional model and the GUNT Media Center give you comprehensive and completely new possibilities to develop the fundamentals of engineering drawing and technical communication in your lessons. You will see and welcome a new enthusiasm among your students and trainees.

You and your students/trainees will work with the GUNT Media Center and the following materials:

- the complete, standard-conforming set of drawings with parts lists
- drawings in PDF, DXF, STP formats
- exploded views
- 3D models of all components with the comprehensive possibilities of the "Autodesk Fusion 360" viewer tool
- many exercise examples with solutions for the teacher/trainer
- and much more...

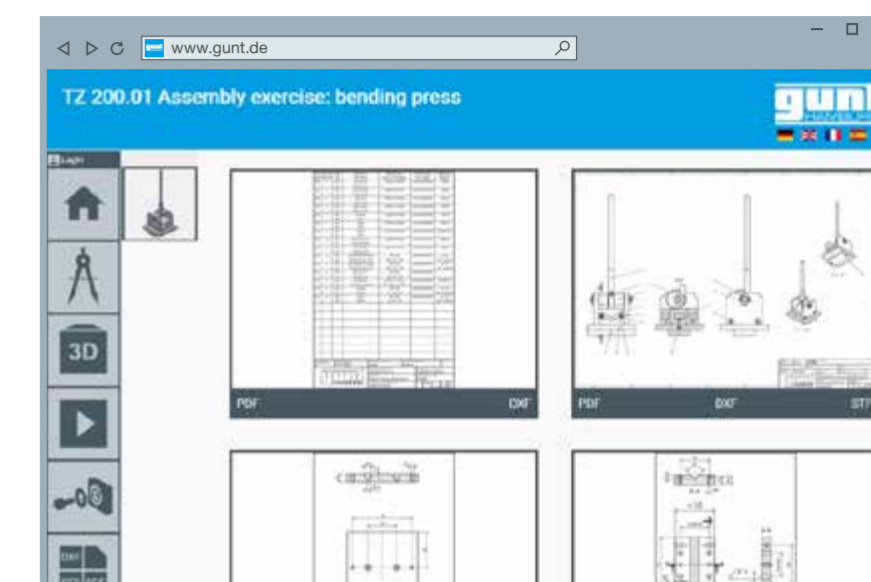

2.3 | Measurement exercises

All production parts are manufactured in accordance with standards and accepted practice. They are ideally suited to exercises on measuring and testing technology, from simple dimensional metrology to tolerance fits. We have provided exercises and solutions for this learning objective area in the GUNT Media Center. All you need to do is provide the necessary measuring instruments and test equipment.

Suggestion for tasks:

Which dimensions for the "side panel" component are important in terms of function and interaction with other parts?

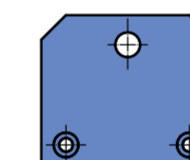

Which dimensions are not important?

There is a hole in the centre into which an axle is inserted. How can the centre distance, from the bottom dimensional reference edge, be determined as accurately as possible?

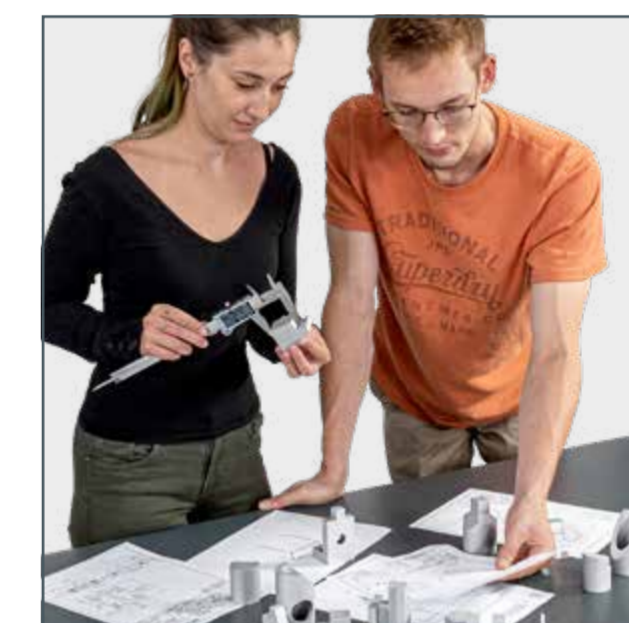

And if you want to go deeper into dimensional metrology, then please take a look at our **DigiSkills 2 Dimensional metrology** learning project.



2.4 | A look at other digital tools and methods

With DigiSkills 1 you and your students/trainees work in a digital environment from the outset. Other digital tools and methods can be studied to develop a broader view. Here are three suggestions:

CAD design

DXF files can be imported into **any** CAD programme. OpenSource CAD programs are also suitable. The **DXF files** can be edited, improved, modified.

...always quite tangibly, starting from the GUNT models.



3D printing

STP files provide an introduction to the topic of parts manufacturing in 3D printing.

Here, too, the GUNT learning project can be followed in a very tangible way.

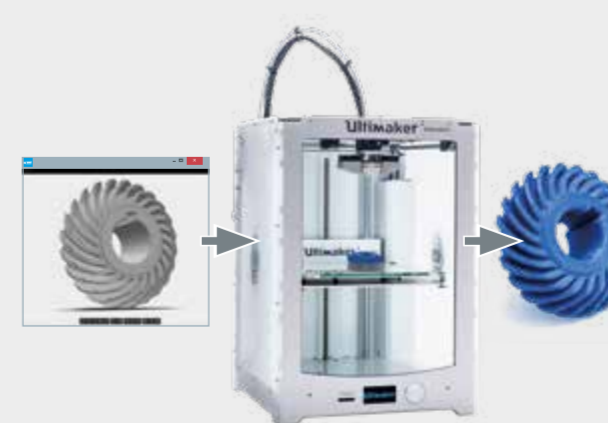

3D scanning

Instead of the 3D model from the design being taken as the basis, a **scan** is used in which the resulting data can be transferred to a CAD application. This is a digital technology that you should demonstrate.

This is where the term 'digital twin' first appears.



Example of a 3D scanner from the company KEYENCE DEUTSCHLAND GmbH

2 | Module 2 Functional models

2.5 | Assembly and assembly planning

Assembling a lever shear or a bending press from the available individual parts is an ideal task to give students/trainees at an early stage of their learning. It is challenging, fun and creates a sense of achievement.

However, assembly processes in an industrial environment do not follow a principle of 'trial and error'. Assembly processes are deliberate, planned in advance and structured. It is important to understand this. The exercises we suggest are designed as an open thought process; there are different ways to reach the goal.

You will find extensive materials on this topic in the GUNT Media Center:

- exploded drawings
- assembly and disassembly videos
- illustrated step-by-step assembly instructions
- structural grid with notes on the assembly process
- ... and much more – all free of charge and without licences, open to you and your students/trainees.

We have suggested an exercise at the end of this section designed to recognise, compare and discuss the versatile approaches to planning and execution.

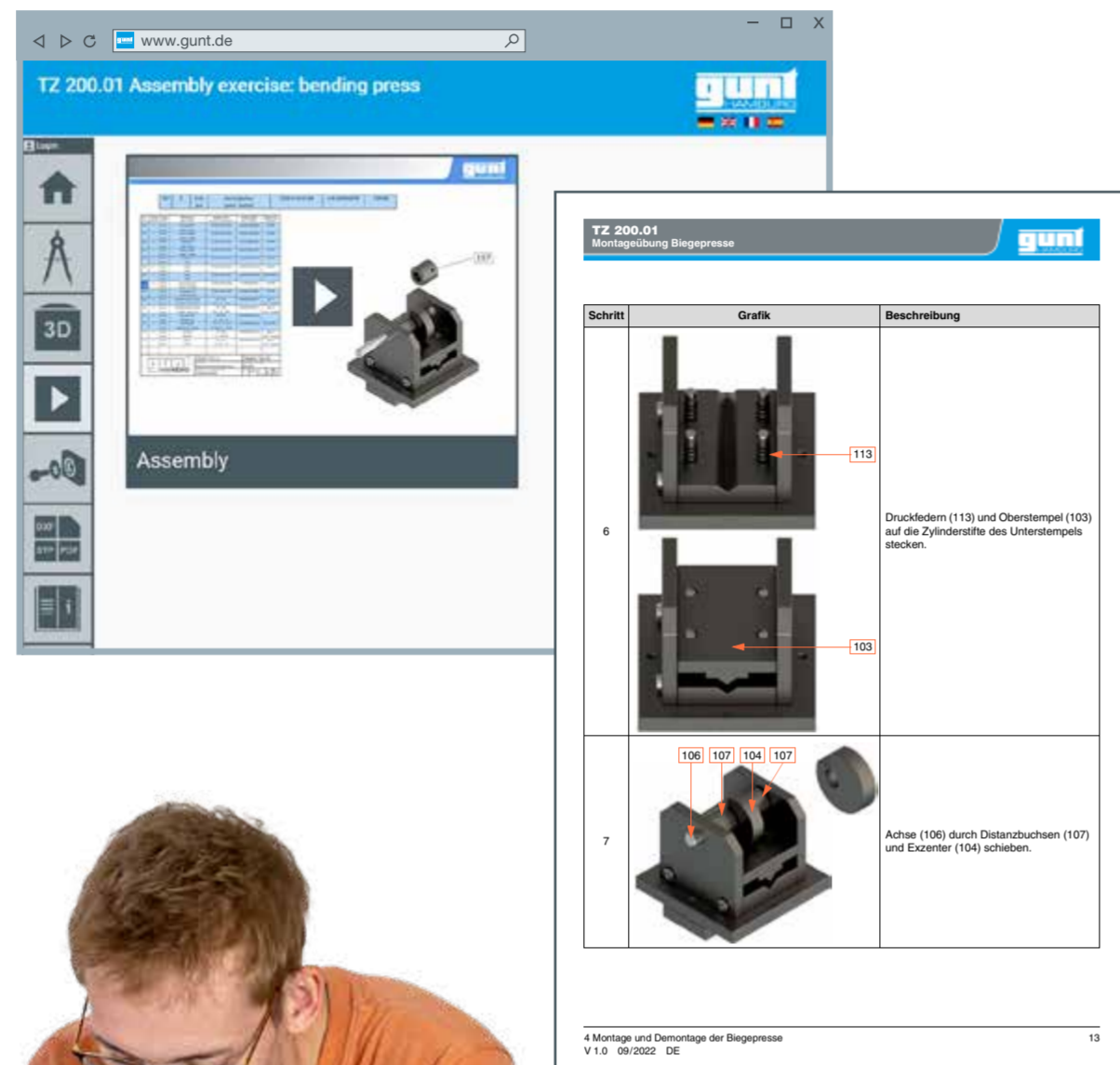

2.6 | Identifying and describing functions

We use the functional models at an early stage of learning and to great success in foundation and preparatory courses.

Technical thinking, recognising and describing functions starts on the very first day. The teachers/trainers encourage and inspire. The students/trainees start thinking about problems, functions and solutions and learn how to articulate them.

Here are a few suggestions for tasks:

Cutting, punching and bending requires a back-and-forth tool movement. How does this movement come about? Investigating and describing the mechanisms can be useful tasks to complement the lessons.

For example, how does the bending press need to be changed if the product of the bending process – the fastening clamp – needs a different shape?

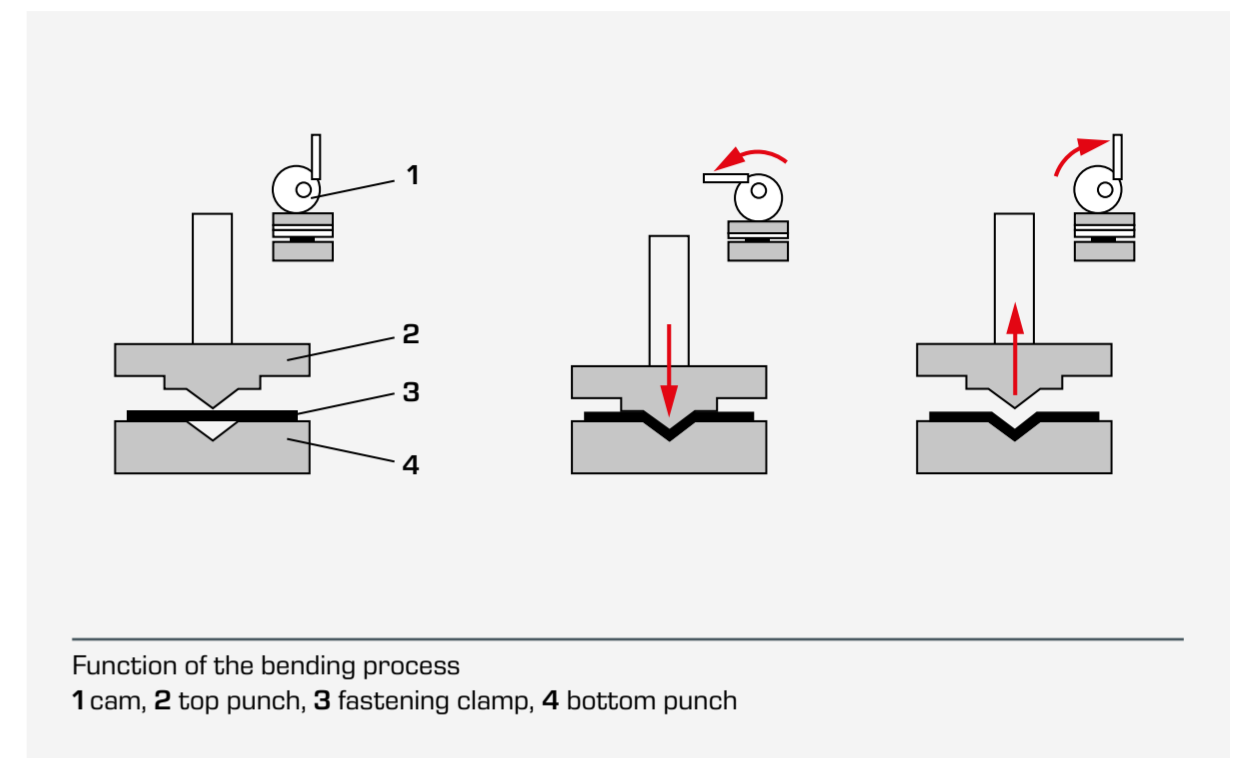

2.7 | The storage system



Each practice kit is clearly laid out and well protected in its own storage system.

Keep everything tidy, neatly arranged and easy to transport and maintain an overview to ensure constant and immediate availability.

Learning content – competence modules, summarised for module 2

Development of digital skills	Traditional, technical content
<ul style="list-style-type: none"> ■ intensive use of digital media and tools, e.g. use of the GUNT Media Center ■ familiarisation with STP, DXF, PDF file formats ■ access a 3D representation from the STP file and use the "Autodesk Fusion 360" viewer tool: scale, rotate, move, cut, measure ■ use standard business software, e.g. Office packages, ERP systems, Computer Aided Design (CAD) ■ create or edit drawings, protocols, work plans ■ use digital learning media, e.g. web-based training (WBT) ■ research information sources and obtain information from digital networks and evaluate information from the Internet, portals, platforms ■ familiarisation with media technology, presentation methods ■ paperless processing of exercises and associated protocols with interactive PDF templates, email communication, video conferencing 	<ul style="list-style-type: none"> ■ developing the fundamentals of engineering drawing in line with practice and standards: sectional views, drawing types, creating parts lists, surface and tolerance specifications ■ differentiation between standard and production parts, familiarisation with important standards ■ distinguishing and naming materials ■ exercises on dimensional metrology: measuring and testing ■ planning and carrying out assembly processes, functional testing ■ understand and describe the function of simple mechanisms, initiate technical thinking, design thinking ■ simple measuring exercises, transferring dimensions to the engineering drawing

2 | Module 2 Functional models

2.8 | Example exercise

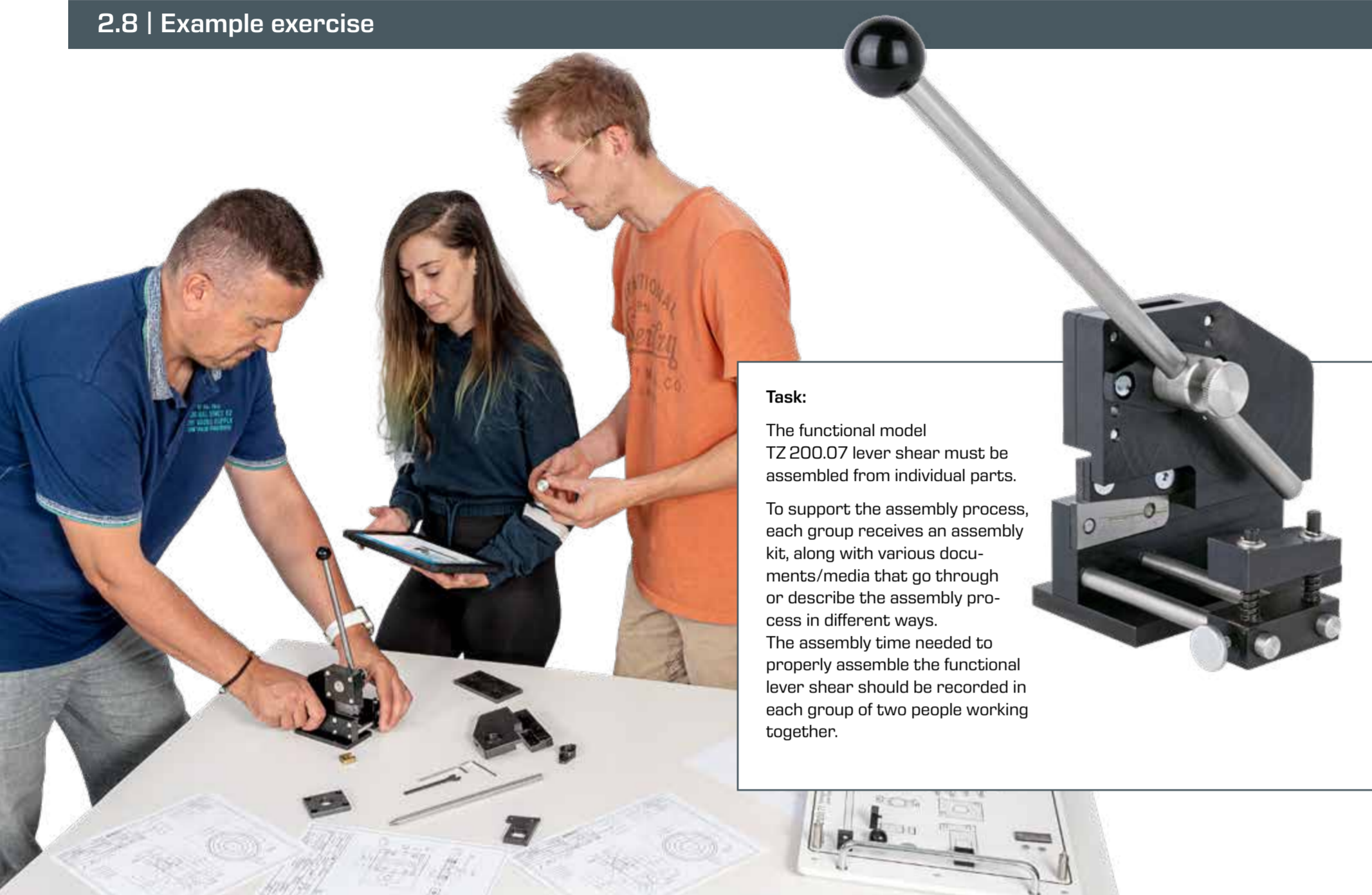

Task:

The functional model TZ 200.07 lever shear must be assembled from individual parts.

To support the assembly process, each group receives an assembly kit, along with various documents/media that go through or describe the assembly process in different ways.

The assembly time needed to properly assemble the functional lever shear should be recorded in each group of two people working together.

Acquire media competence

- recognise that assembly is a planned, systematic process that is described or supported by different media/representations
- familiarisation with different ways and methods of technical communication and be able to explain them
- be able to present findings and work results with digital tools, including in front of a larger learning group
- understand and use media diversity
- recognise the capability and communication advantages of digital media, as compared to traditional media



General conditions

- 20 to 24 students in one class
- lesson time: 90 minutes
- professions: all metalworking professions and comparable professions
- education year: from the 1st year of education, also suitable for higher years depending on specialisation

Lesson organisation

- start input by the trainer/teacher
- team work takes place in pairs, each with emphasis on different entry requirements
- the different teams present their work results
- trainers/teachers systematise and ensure lasting results

Materials/media

- 1 functional model of lever shear, fully assembled
- 10-12 assembly sets TZ 200.07 Lever shear, in individual parts
- access to the GUNT Media Center with all relevant digital content; teacher/trainer selects the materials

Learning objectives/learning areas

Some points from the skilled occupation of **industrial mechanic**

- digitalisation of work
- operational and technical communication
- planning and organising work, evaluating work results
- manufacturing, assembling and disassembling components, assemblies and systems

Different approaches to assembly

<p>1 Assembly kit on a tablet and a fully assembled lever shear as a real-world "model"</p>	<p>2 Exploded drawing from the GUNT Media Center. The drawing can be viewed in the Media Center or downloaded and printed out.</p>
<p>3 Overall drawing as a traditional engineering drawing and the parts list from the GUNT Media Center. The drawing can be viewed in the Media Center or downloaded and printed out.</p>	<p>4 Assembly instructions as a paper printout from the GUNT Media Center. The assembly process is shown and explained step-by-step.</p>
<p>5 Symbolic assembly structure, which lies over the assembly kit as a transparent cover plate.</p>	<p>6 3D model in STP format from the GUNT Media Center. Many details in the 3D model are clearly visible to allow the assembly process to be carried out accurately.</p>
<p>7 Assembly video from the GUNT Media Center. The video contains an integrated parts list.</p>	<p>8 3D model of the assembled lever shear, accessible via a link opened in a browser. Based on scan data.</p>
<p>9 Assembly kit on a tablet without further tools. The assembly process intuitively follows the principle of trial and error.</p>	<p>10 These different technical communication tools are designed to be presented by students at the end of the exercise.</p> <ul style="list-style-type: none"> ■ how did you arrive at the result? ■ what tools did you have to support you? <p>This gives the whole group an overview of the variety of media.</p> <ul style="list-style-type: none"> ■ Comparisons and evaluations can be made. ■ which method do you think is best? ■ which method is particularly challenging? ■ how should you not approach the task?

3 | Module 3 Developing the fundamentals of Geometrical Product Specifications

3.1 | ISO GPS, introduction to Geometrical Product Specifications

The fundamentals:

ISO GPS is the most important standardisation system in technical communication. All standards dealing with the requirements for the geometry of components (workpieces) are a part of it. The **Geometrical Product Specification (GPS)** is the basis for communication between design, manufacturing and quality assurance. The aim is to ensure the functionality and usability of components. ISO GPS is a system of standards for **uniformly describing and checking workpiece properties**, such as size dimension, orientation, location, form, surface characteristics, etc.

Since DIN EN ISO 8015, GPS came into force in 2011, there have been changes in dimensioning and tolerancing in engineering drawings. New symbols and new terms have become more and more established.

Two examples illustrate these changes:

Example of ambiguous dimensioning of a linear distance between two holes

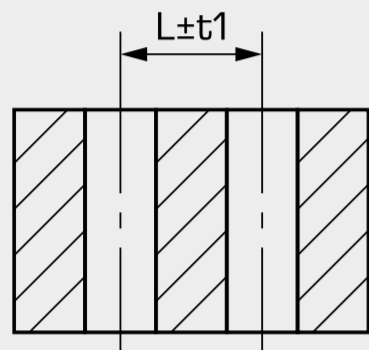

Previous dimensioning of two holes. The position and therefore the distance of both centre lines is ambiguous.

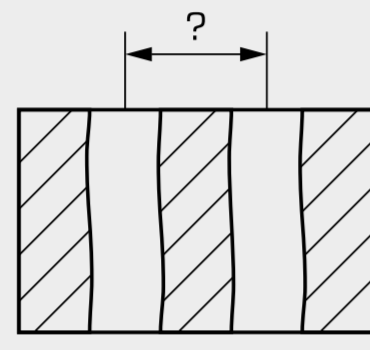

Real holes. How should the centre lines be measured?

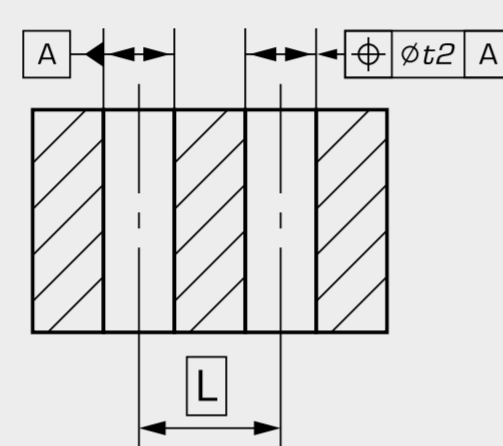

Suggestion for unambiguous dimensioning with reference and geometric specification.



Reference plane **A** is defined.

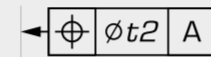

The position is specified as the location tolerance. Thus the distance between the centre lines is tolerated by the position tolerance zone with the theoretically exact dimension **L**.



Theoretically exact dimension.

Example of ambiguous dimensioning of a linear distance between two parallel edges

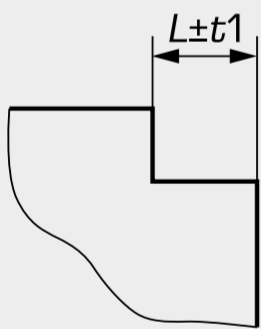

Previous dimensioning of the distance. Location and orientation of the tolerated dimension are ambiguous.

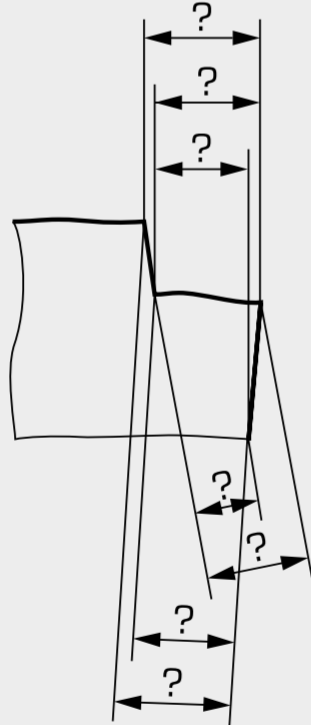

Real component. Form and direction tolerances are not specified. In which direction should the measurement be taken?

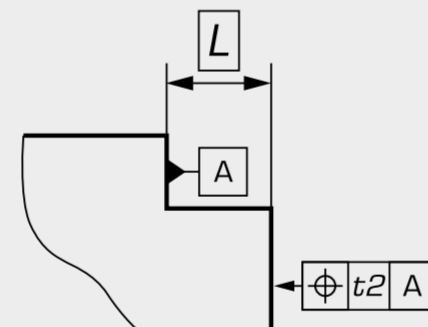

Suggestion for unambiguous dimensioning with reference and geometric specification.



Reference plane **A** is specified at one of the surfaces.

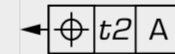

The position is specified as the location tolerance. The distance between the surfaces is tolerated by the position tolerance zone with the theoretically exact dimension **L**.



Theoretically exact dimension.

Future skilled workers – today's students – must know the GPS basics and be able to read and understand current drawings.

A proven suggestion from GUNT: the learning process to develop **GPS fundamentals** should not be too formal or abstract. Take the MT121 mitre gear assembly exercise as the basis. This puts you firmly at the heart of industrial practice.

Let the students assemble/disassemble the gear before you talk about GPS. Components and functions are understood. Technical thinking is developed. Then go to the GUNT Media Center, where you will find the complete set of drawings, designed for production and in accordance with GPS.

Here is a tangible exercise: reading and understanding drawings with a GPS view.

3.2 | MT 121 Assembly exercise: mitre gear

The MT 121 assembly kit is designed for training at vocational schools and company training centres. The close link between theory and practice-based learning content is evident.



The MT 121 assembly exercise is perfect as preparation for in-depth study of the topic of GPS. The teaching material includes:

- complete set of drawings as DXF, STP and PDF files
- part lists
- 3D models for all components, which can be viewed with the extensive possibilities of the A360 viewer tool
- many exercise examples with solutions for the teacher/trainer

All drawings are to standard and dimensioned in accordance with production requirements. The assembly videos are also very useful. All of which can be accessed via the GUNT Media Center.

- assembly and disassembly can be carried out within normal teaching units
- only simple tools required
- the fit seatings of the gear unit are designed to allow the complete assembly process to be carried out by hand
- Augmented Reality (AR) interface for information retrieval



The mitre gear as an assembly kit and fully assembled



Augmented Reality (AR) interface for information retrieval

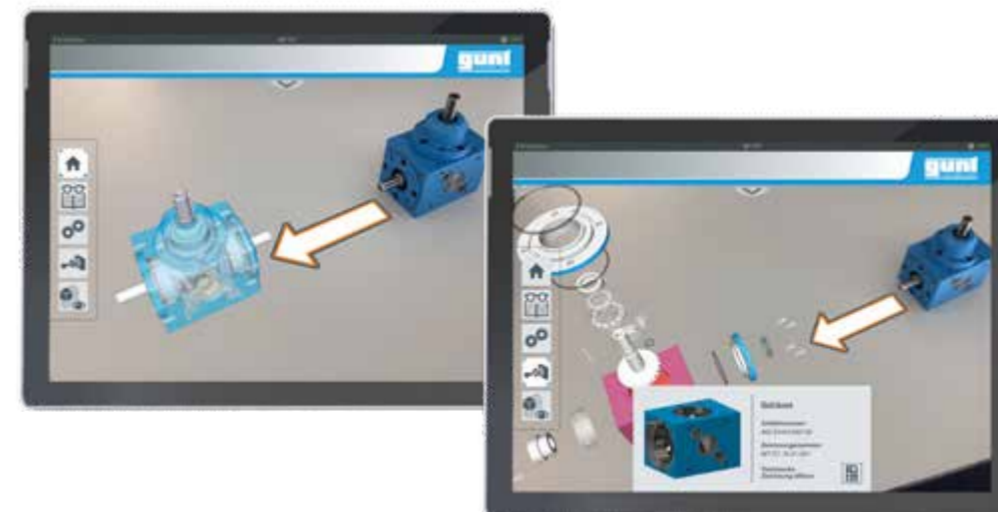

Advanced topics

- creating programmes for 3D printing and CNC machining
- assembly and disassembly, including for the purposes of maintenance and repair
- planning and presentation of the assembly process
- familiarisation with various machine elements: ball bearings, shaft seals
- familiarisation with assembly aids and devices
- and much more...

3 | Module 3 Developing the fundamentals of Geometrical Product Specifications

3.3 | Example exercise: reading and understanding drawings with a GPS view

Suggested exercises:

Based on the standards-compliant symbols in the individual part drawing, the directional, spatial and running tolerances must be interpreted correctly. The information is then assigned to the corresponding GPS standards.

All required drawings and the 3D model are available in the GUNT Media Center.



3D This button takes you to the 3D model of the component, which you can explode into its individual parts



3D This button takes you to the 3D model of the component, which you can explode into its individual parts

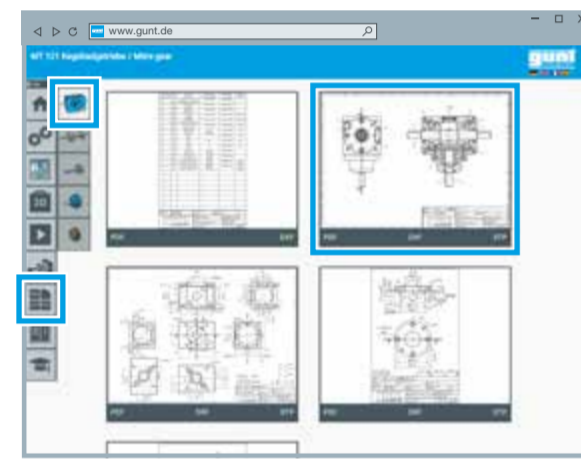

This button takes you to the overall and individual part drawings in DXF, STP and PDF format

Task for the "Output shaft" component:

1 what do the following details in the drawing mean and how do they relate to each other?

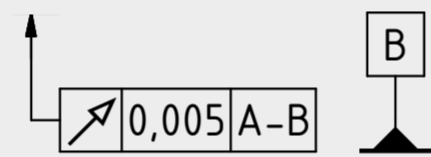

2 to which GPS standard can the information be assigned?

Task for the "Driven shaft bearing cap" component:

1 what is the significance of the following details on the dimension in the drawing?



2 to which GPS standard can the information be assigned?

Additional task:

1 what is the significance of the following information?

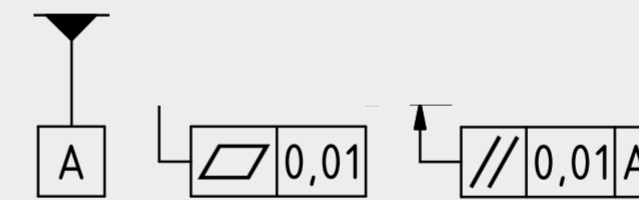

2 to which GPS standard can the information be assigned?

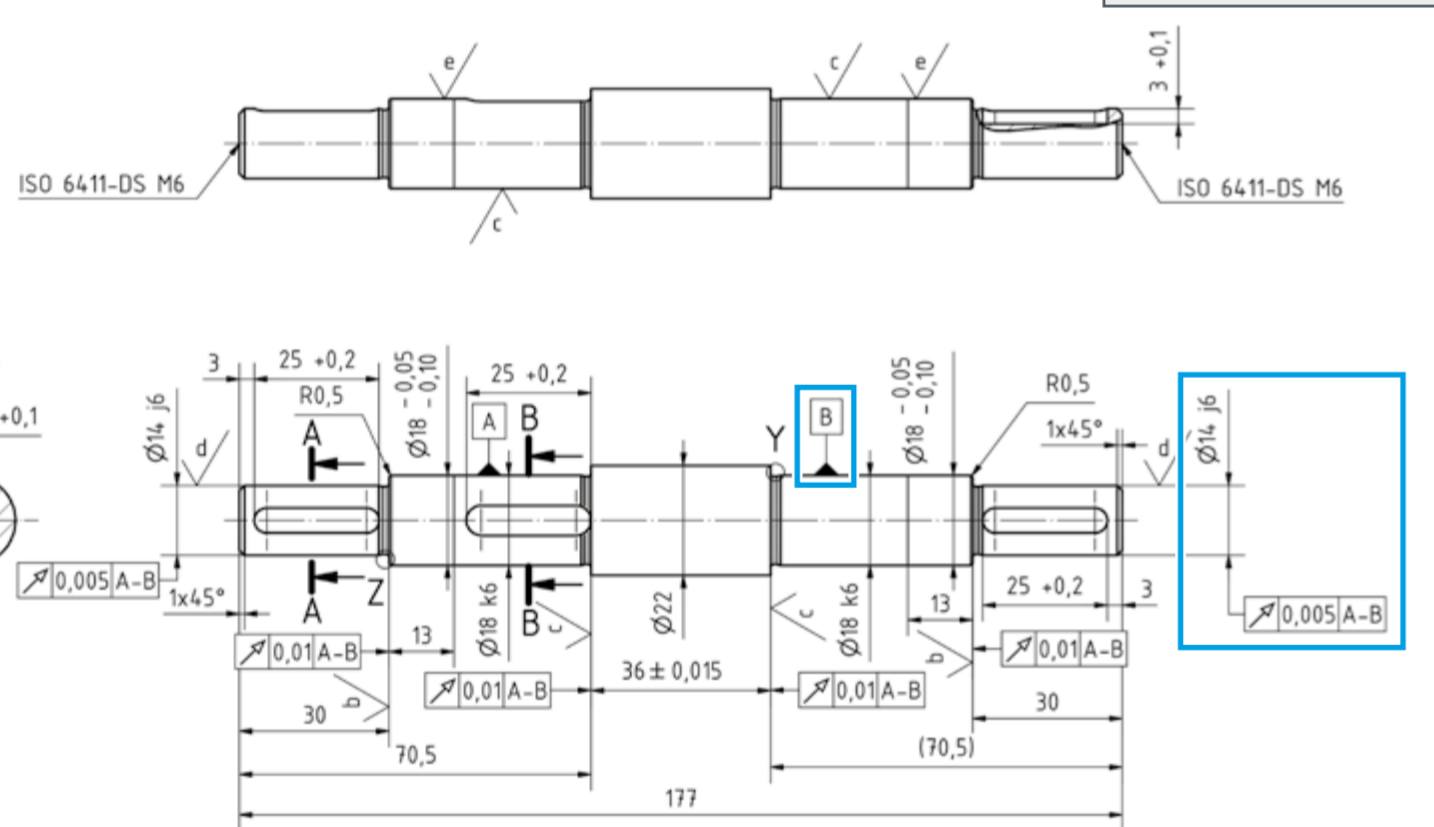
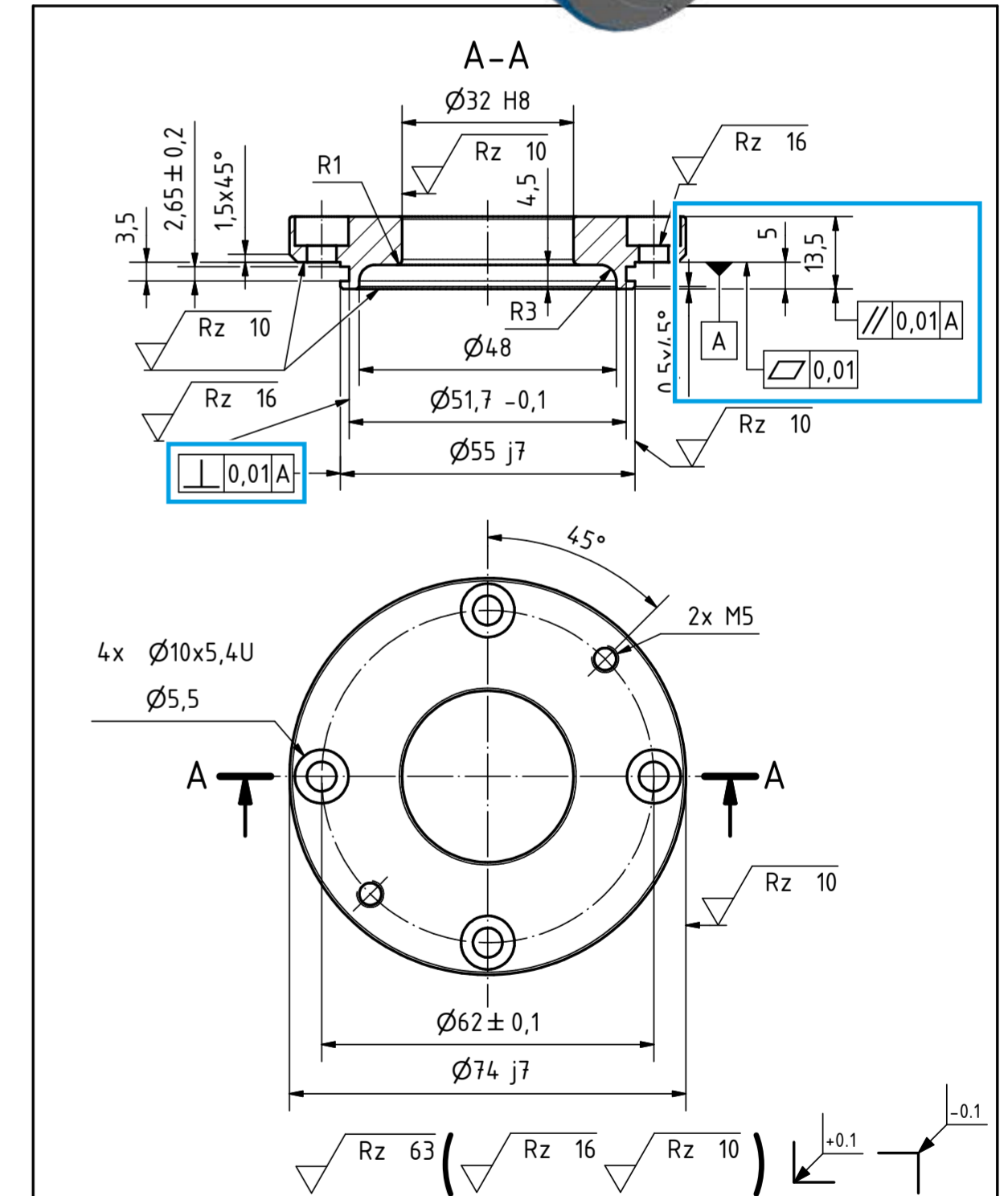

- a/ = Rz 63
- b/ = Rz 16
- c/ = geschliffen/ grinded
- d/ = Rz 4
- e/ = Rz 10
- Einstich geschl./ recess grinded
- Rmax = 4µm

Important GPS standards for geometrical definition of a workpiece	
Complementary GPS standards	
DIN EN ISO 8062-3	General dimensional and geometrical tolerances and machining allowances for castings
DIN EN ISO 1660	Geometrical tolerancing – Profile tolerancing
General GPS standards	
DIN EN ISO 14405-1; -2; -3	Dimensional tolerancing – Linear sizes; Dimensions other than linear or angular sizes; Angular sizes
DIN EN ISO 286-1; -2	ISO code system for tolerances on linear sizes – Tolerances, deviations and fits, tables
DIN EN ISO 1101	Geometrical tolerancing – Tolerances of form, orientation, location, run-out
DIN EN ISO 21920-1; -2; -3	Surface texture or profiles: Indication of surface texture, terms, definitions and parameters, specification operators
Fundamental GPS standards	
DIN EN ISO 8015	Fundamentals – Concepts, principles and rules
DIN EN ISO 14638	Matrix model

Maßstab/ Scale: 1:1	Position/ Item: 200	Werkstoff/ Material: C60
Einzelteilzeichnung/ Single part drawing	freigegeben/ approved	
Abtriebswelle/ Driven shaft	426.00310A00100	
MT121.10.02.001	2018-03-26	1/1

Maßstab/ Scale: 1:1	Position/ Item: 104	Werkstoff/ Material: EN-GJL-250
Einzelteilzeichnung/ Single part drawing	freigegeben/ approved	
Abtriebsdeckel/ Driven shaft bearing cap	403.10237A00101	
MT121.10.01.002	2018-03-26	1/1

4 | Learning contents

The entire DigiSkills 1 learning project is structured in development levels A, B, C and D, which are perfectly balanced in terms of demand and complexity. DigiSkills 1 can accompany you throughout the entire training course.

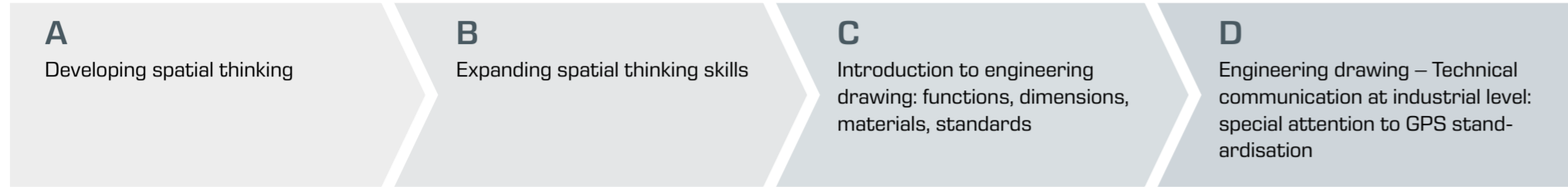

Traditional, technical content

The learning vehicles of the DigiSkills 1 learning project offer almost infinite possibilities of traditional learning content and your lessons can draw from many areas of learning to target appropriate learning objectives.

<p>Engineering drawing – Technical communication</p>	<ul style="list-style-type: none"> three-view display and step-by-step development of spatial thinking skills producing drawings that conform to standards reading and understanding more complex drawings build technical communication skills in the subject area: technical terms, variety of media, presentations 	
<p>Measuring, testing</p>	<ul style="list-style-type: none"> familiarisation with simple steps of measurement and metrology quality monitoring based on specific GPS requirements learn the basics of GPS symbols 	
<p>Production, materials</p>	<ul style="list-style-type: none"> distinguish between materials, know material standards know basic manufacturing processes and assign them to the drawing specifications 	
<p>Function, design</p>	<ul style="list-style-type: none"> recognise and describe technological functions in simple mechanisms and machine elements work out variants in design and functions 	
<p>Assembly, standard parts</p>	<ul style="list-style-type: none"> plan and carry out assembly; describe assembly processes distinguish between production parts and standard parts parts lists, standard designations 	
<p>Calculations</p>	<p>Simple calculations, such as</p> <ul style="list-style-type: none"> weight calculations lever principle transmission ratio strength 	

The GUNT DigiSkills learning projects

Digitalisation of the world of work – new requirements for the professional world

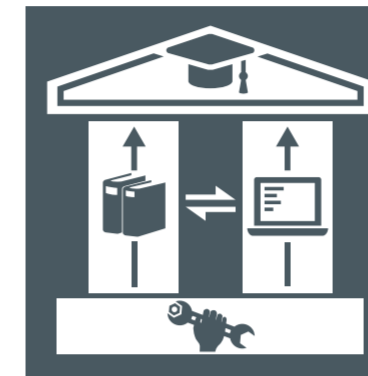

The model for hybrid learning goal development

All GUNT DigiSkills learning projects follow the model of **hybrid learning goal development**: traditional subject-specific learning goals are achieved in parallel and integratively with the development of digital skills. Always in a practical environment.



Prof. Dr. em. Jörg-Peter Pahl, TU Dresden, Institute for Vocational Education

The scientist's opinion

With the GUNT DigiSkills learning projects, GUNT has introduced an important didactic-methodological concept that ideally meets today's demands for the digitalisation of the world of work.

The new concept for **hybrid learning goal development** will – as is to be expected – be warmly received in the training and teaching process. The main features are:

- vertical integration of competence development
- practical learning environment
- learning situations are always real-world, but digitally supported throughout

Development of digital skills

How to achieve the digital transformation to Industry 4.0

With the GUNT DigiSkills 1 learning project, the following modules for the development of digital competences are achievable:

- using web portals as a source of information: data from the GUNT Media Center, accessed via QR code or link
- familiarisation with various practical file formats: PDF, DXF, STP, etc.
- use standard business software, e.g. Office packages, ERP systems, Computer Aided Design (CAD)
- create or edit drawings, protocols, work plans
- use digital learning media, e.g. web-based training (WBT)
- research information sources and obtain information from digital networks and evaluate information from the Internet, portals, platforms
- media technology, presentation methods
- paperless processing of exercises and associated protocols, interactive PDF templates, email communication, video conferencing
- use Augmented Reality (AR) to obtain information
- natural and stress-free immersion in the digital methods and tools of the modern world of work with GUNT DigiSkills 1 learning project
- develop necessary digital skills step-by-step, simply from "common" problems
- no abstract, detached efforts to address digital technologies; everything is integrative and relevant; there are no questions of "why do I need this?"

GUNT DigiSkills – different levels of requirements

1 Engineering drawing – Technical communication

2 Dimensional metrology

3 Preventive maintenance

4 Energy efficiency in compressed air systems

5 Robotics and automation

The GUNT Media Center as a gateway to Education 4.0

- no additional licences necessary
- access to the GUNT Media Center comes with the products you purchase from GUNT
- no limit to the number of participants
- full availability everywhere and 24/7
- data always up-to-date
- free download
- available online and offline
- can be accessed from any device (notebook, tablet, smartphone)
- all that's required is a stable internet connection



5 | What students and teachers say

Product designer

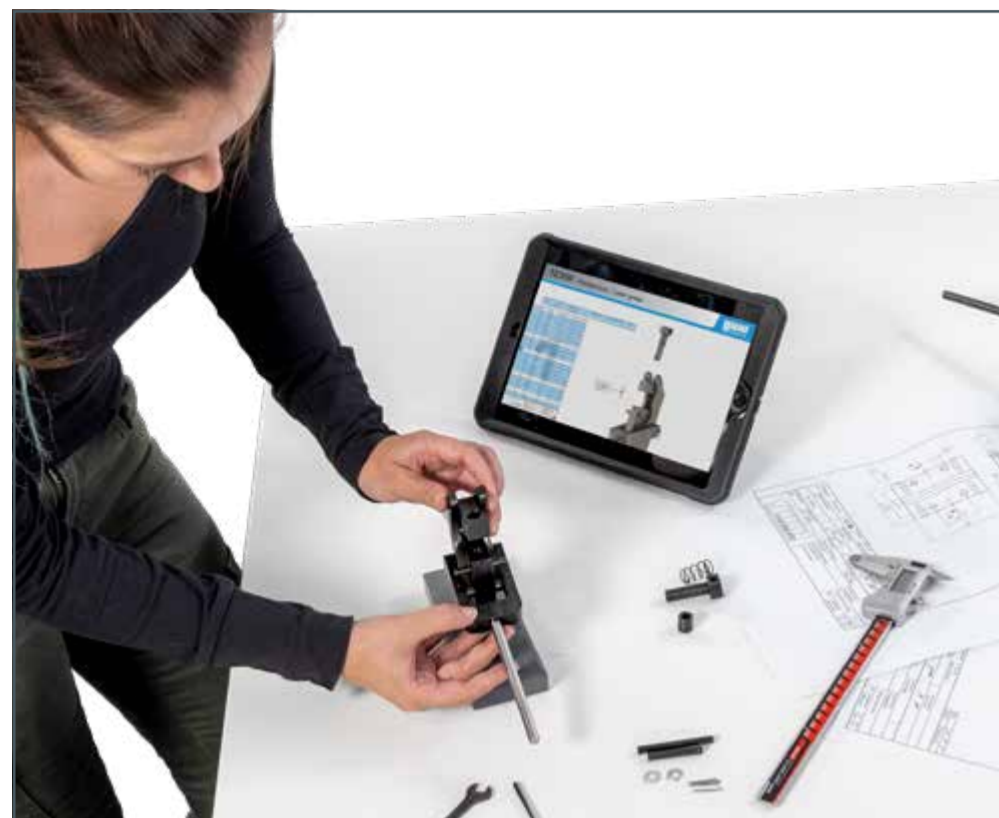

What prompted you to do vocational training in a technical profession?

Three years ago, my sister did a vocational course as an industrial mechanic specialising in precision engineering. Through this I discovered engineering and the processes involved.

Was there anything in your sister's course that you didn't like so much?

I noticed that she had to work with paper documents only. In my sister's lessons there was nothing to grasp hold of. I would have had problems understanding complex topics in a theoretical environment like that.

What did you do in our sample lesson today and how did you find it?

Today we assembled the lever shear and went into a wide variety of questions. I'm really excited, it's rare for me to be able to follow an instructor or teacher so well.

What would you say to your instructor/teacher after this experience?

I think practical projects like these should be done much more often in class.

It was much easier for me to understand the context and meaning of the tasks, and the questions to my instructor were much more practical-oriented. The GUNT Media Center is great too; we don't often have so many modern and different media in school.

Teacher

How did you find our sample lessons with your students?

For me, too, GUNT's "DigiSkills" approach – assembling the lever shear – with the versatile digital media support was a real experience.

How would you rate the cooperation between your students?

It went very well. Everyone was fully engaged, the versatility of the media and the practical part of the lesson held the attention of the whole class. Every one of the students was focused and attentive, even the ones I thought were playing on their phones again were actually in the GUNT Media Center getting information.

What can you take away from this experience for your future teaching?

I had no idea what I could get out of digital elements for these fundamental topics. I also intend to incorporate a lot more practical elements into my teaching. We are continuing on this path, together with GUNT.

What tips do you have for your colleagues on the subject of digitalisation?

I can only recommend that all colleagues in metalworking technology take a look at these new didactic concepts from GUNT.



How do we get talking?

DigiSkills seminars for teachers and trainers

You are interested in getting to know our DigiSkills 1 learning project closer and LIVE?

Arrange an appointment

sales@gunt.de



Further training for teachers and trainers

- all technical topics related to our DigiSkills learning projects
- at a high level didactically
- adapted to your specific needs

Practical demonstrations at your school/training centre

- you set the subject area
- we come to you and bring everything for a successful demonstration
- students and trainees are welcome
- we know real teaching practices; we can teach too

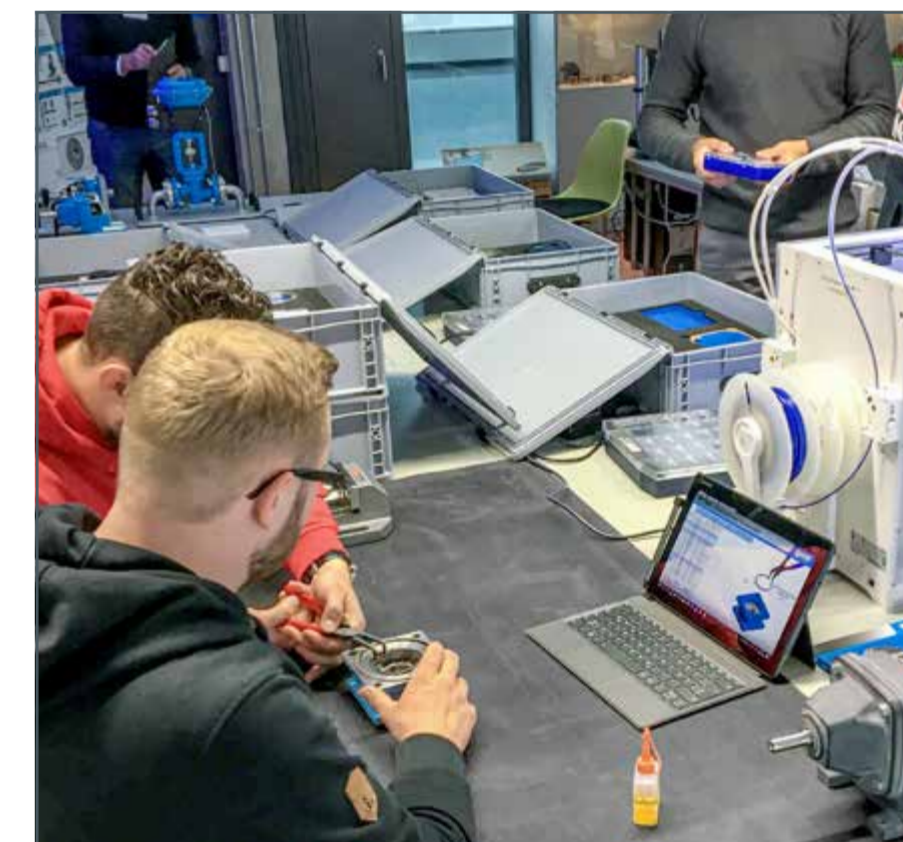

* For data protection reasons we have only published the first names of the persons involved. Those involved have agreed to this publication.

6 | Product list and tender specifications

Product list

Practice kits for engineering drawing, geometric models

TZ 100 Spatial imagination with three-view display

TZ 110 Cylindrical models with cuts parallel to axis

TZ 120 Cylindrical models with slanted cuts

TZ 130 Prismatic models with cuts parallel to edges

TZ 140 Prismatic models with slanted cuts

To do exercises in small groups, you will need more of each TZ product. You can work with six of each but 12 sets of a product are best in terms of optimal design and effectiveness of the exercises.

The mitre gear assembly exercise can be done with just one product if the demonstration is the main focus.

Practice kits for engineering drawing, functional models

TZ 200.01 Assembly exercise: bending press

TZ 200.07 Assembly exercise: lever shear

TZ 300 Assembly exercise: lever press

Assembly kit

MT 121 Assembly exercise: mitre gear

Tender specifications

Here we provide text describing the overall concept of **GUNT DigiSkills 1**. The complete tender specifications for individual products can be found on the GUNT website, on the page for the specific product. The texts provided there are ideally suited for constructing a call for tenders, together with the text you will find here. We are always available to help you set up a call for tenders.

The DigiSkills 1 learning project provides comprehensive exercises in engineering drawing and technical communication. The learning level ranges from "beginner" to "expert". The project includes nine didactically related practice kits. Of these, five practice kits are intended for the development of fundamentals and three for a deeper technical understanding. These practice kits are designed according to purely didactic approaches to support the learning process.

The final practice kit is based on a modern industrial mitre gear, which is used specifically to practise GPS standardisation.

The storage system for each practice kit, consisting of a plastic case with foam inlay, contains all the elements required for an exercise. The storage system is space-saving, easy to transport and ensures many years of availability.

For each TZ/MT practice kit that is part of the DigiSkills 1 learning project, there is access to the online GUNT Media Center portal. The access licence to the GUNT Media Center is acquired when you purchase the hardware and is not subject to any further conditions or restrictions. Extensive digital materials are available in the GUNT Media Center: standard-compliant drawings of the components, assembly and disassembly videos, exercises and solutions.

In addition to the achievement of systematic and versatile learning contents of engineering drawing and technical communication, the courses develop comprehensive digital skills through vertical integration and a focus on projects. With the complete system of GUNT DigiSkills 1 – Engineering drawing – Technical communication, the following modules for the development of digital competences must be achievable:

- using web portals as a source of information: data from the GUNT Media Center, accessed via QR code or link
- familiarisation with various practical file formats: PDF, DXF, STP, etc.
- use standard business software, e.g. Office packages, ERP systems, Computer Aided Design (CAD)
- create or edit drawings, protocols, work plans
- use digital learning media, e.g. web-based training (WBT)
- research information sources and obtain information from digital networks and evaluate information from the Internet, portals, platforms
- media technology, presentation methods
- paperless processing of exercises and associated protocols, interactive PDF templates, email communication, video conferencing



7 | Summary and outlook for further DigiSkills learning projects

Our DigiSkills 3, 4 and 5 learning projects deal with a concrete, real-world project. There is an engineering-related task to be completed or a project goal to be achieved in stages.

In the DigiSkills 1 and 2 learning projects, the project goal is more focused on the development of comprehensive fundamentals. The acquisition of a comprehen-

sive range of learning objectives is ensured by the fact that we have compiled the DigiSkills 1 learning project from several products. The products suggested here can also achieve excellent results when used individually. This does not result in any didactic disadvantages, merely in a reduction of the scope.

DigiSkills learning project no.	Subject area	Learning objective areas/ Features	Focus
1	Engineering drawing – Technical communication	<ul style="list-style-type: none"> ■ fundamentals of engineering drawing ■ geometric models, functional models ■ Geometrical Product Specifications (GPS) ■ constructive thinking, machine elements, materials 	Metalworking professions
2	Dimensional metrology	<ul style="list-style-type: none"> ■ fundamentals of inspection technology: testing, measuring, gauging ■ familiarisation with measuring instruments ■ Geometrical Product Specifications (GPS) ■ surface marking, fit systems 	Metalworking professions
3	Preventive maintenance	<ul style="list-style-type: none"> ■ design and function of a sorting plant ■ predictive maintenance, condition monitoring ■ assembly and disassembly, functional testing, commissioning ■ machine elements, materials 	Mechatronics, Metalworking and electrical professions
4	Energy efficiency in compressed air systems	<ul style="list-style-type: none"> ■ design and function of a compressed air system ■ assembly and functional testing of compressed air generators ■ systematic optimisation of modern compressed air systems ■ representation of energy flows 	Mechatronics, Metalworking and electrical professions
5	Robotics and automation	<ul style="list-style-type: none"> ■ robot-supported materials testing ■ mechanics, hydraulics, pneumatics, electrics ■ control system, PLC programming ■ sensors and actuators ■ system integration ■ process integration 	Mechatronics, Metalworking and electrical professions



Contact

G.U.N.T. Gerätebau GmbH
Hanskampring 15 - 17
22885 Barsbüttel
Germany
+49 40 6708 54 - 0
sales@gunt.de
www.gunt.de

Imprint

© 2023 G.U.N.T. Gerätebau GmbH. Any reuse, storage, duplication and reproduction – even in extracts – is prohibited without written approval. GUNT is a registered trademark. Our products are protected by and subject to copyright law.

No warranty shall be assumed for printing errors. Subject to change without notice.

Image credits:
G.U.N.T. Gerätebau GmbH,
manufacturer photos, Shutterstock.
Design & typesetting:
Profisatz.Graphics, Bianca Buhmann,
Hamburg.
Printed on chlorine-free, environmen-
tally friendly paper.



Visit our website
www.gunt.de

