



GUNT RHLine Renewable Heat

HL 320 – Solar thermal energy and heat pump modular system



Subject areas – inclusion of renewable energies

Our HL 320 modular system covers essential Subject Areas from the field of renewable energy usage in building services engineering. The HL 320 modular system allows you to investigate heating systems with various renewable and traditional energy sources. Solar thermal energy can be combined with heat generation from heat pumps. The modular concept of the HL 320 system allows you to create a variety of configurations.

Subject areas

Products

HL 320 Solar thermal energy and heat pump modular system

Possible applications of modern heat pumps

HL 320.01
Heat pump

Combination of regenerative and conventional heat sources

HL 320.02
Conventional heating

Solar thermal heat generation

HL 320.03
Flat plate collector

HL 320.04
Evacuated tube collector

Storage in regenerative heating systems

HL 320.05
Central storage module with controller

Heat sources and heat sinks

HL 320.07
Underfloor heating / geothermal energy absorber

HL 320.08
Fan heater / air heat exchanger

GUNT RHLine Renewable Heat Solar thermal energy and heat pump modular system

The HL 320 modular system allows you to investigate heating systems with various renewable and traditional energy sources. Solar thermal energy can be combined with heat generation from heat pumps. The modular design of the

HL 320 system makes it possible to achieve different combinations and configurations.



Combined use of renewable heat sources

Doing away with a conventional heating system represents a genuine alternative for modern residential buildings with good thermal insulation in many cases. The combination of solar

thermal collectors with a heat pump very often guarantees significant savings with reliable year-round supply.

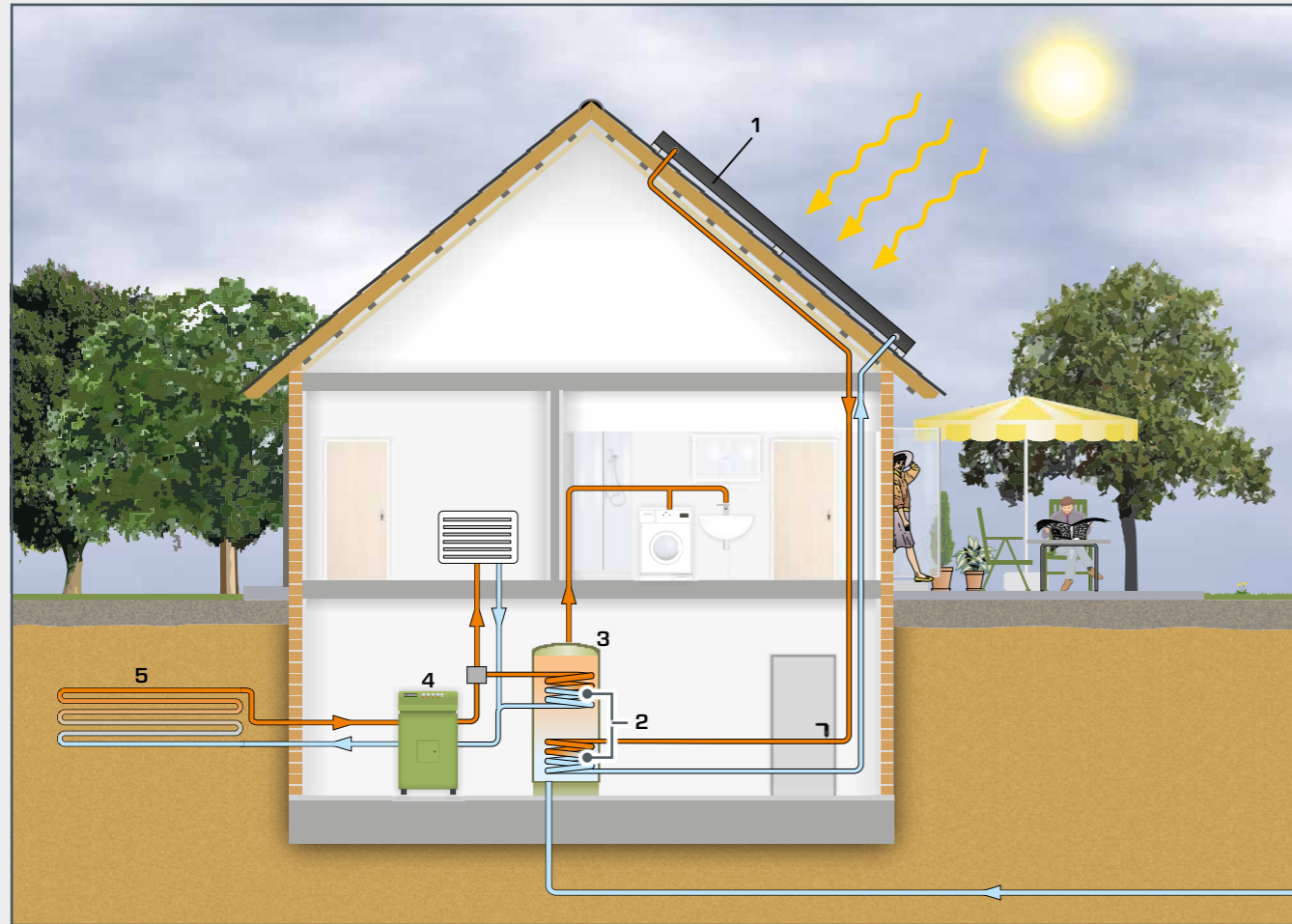

1 flat collector, 2 heat exchanger, 3 hot water storage tank, 4 heat pump, 5 geothermal energy absorber;
 hot heat transfer fluid,
 cold heat transfer fluid,
 reffridgerant, high pressure,
 reffridgerant, low pressure

HL 320.01
Heat pump

HL 320.02
Conventional heating

HL 320.03
Flat collector

HL 320.04
Evacuated tube collector

HL 320.05
Central storage module with controller

The storage module provides bivalent storage and buffer storage. The controller can be used to log measured values over longer periods for analysis of the system behaviour.

HL 320.07
Underfloor heating/
geothermal energy
absorber

HL 320.08
Fan heater/
air heat exchanger

The HL 320.07 and HL 320.08 modules can be used as heat sources or as heat sinks.

Freely programmable controller with extensive software

GUNT RHLine Renewable Heat Solar thermal energy and heat pump modular system

The right configuration for every application

In heating technology, both correct composition of necessary components and optimisation of cabling and controller settings depend on the local conditions. GUNT has developed experiments for a selection of relevant module combinations in order to be able to teach the corresponding learning content in balanced steps. In addition, you may of course create your own system configurations to investigate further issues from the field of regenerative heating technology.

- hot heat transfer fluid,
- cold heat transfer fluid,
- reffridgerant, high pressure,
- reffridgerant, low pressure

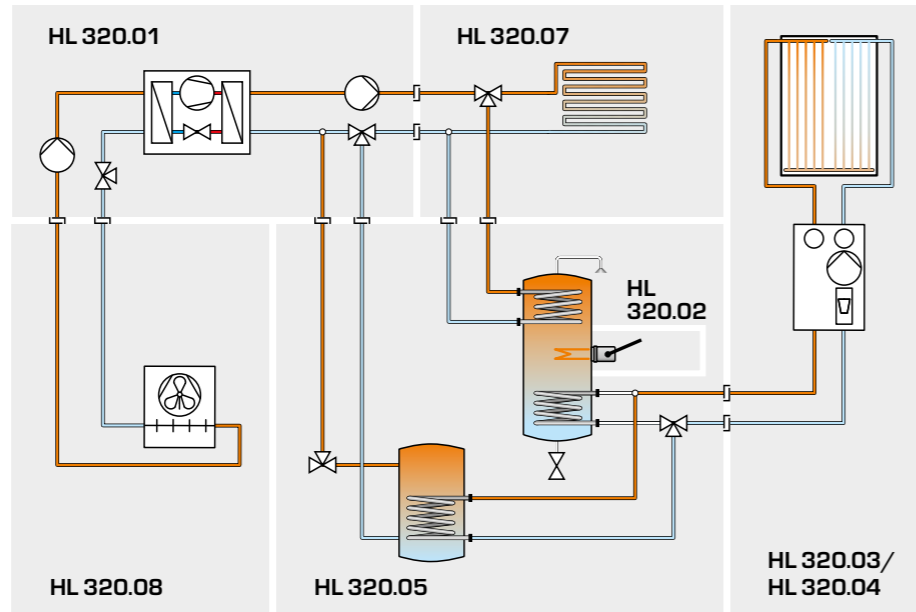

Example for a system diagram for complementary heating and domestic water heating with a solar thermal collector and a heat pump (combination 5).



Recommended combinations for the HL 320 modular system					
Combi-nation ▶	1	2	3	4	5
HL 320.01 Heat pump					
HL 320.02 Conventional heating					
HL 320.03 Flat collector					
HL 320.04 Evacuated tube collector					
HL 320.05 Central storage module with controller					
HL 320.07 Underfloor heating / geothermal energy absorber					
HL 320.08 Fan heater / air heat exchanger					

Learning objectives and experiments

Combination 1

- function of a solar thermal heating system
- commissioning
- collector efficiency and losses

Combination 2

- combined use of traditional and solar thermal energy
- efficient indoor heating with underfloor heating

Combination 3

- function and design of a heat pump
- parameterisation of a heat pump controller
- factors influencing the COP (Coefficient of Performance)

Combination 4

- efficient use of solar thermal and geothermal energy
- strategies for heat supply in various consumption profiles

Combination 5

- use of renewable and fossil fuels for heating and hot water
- bivalent parallel and bivalent alternative heat pump mode

HL 320.01 Heat pump

Network capability: observe, acquire, analyse experiments via customer's own network



About the product:

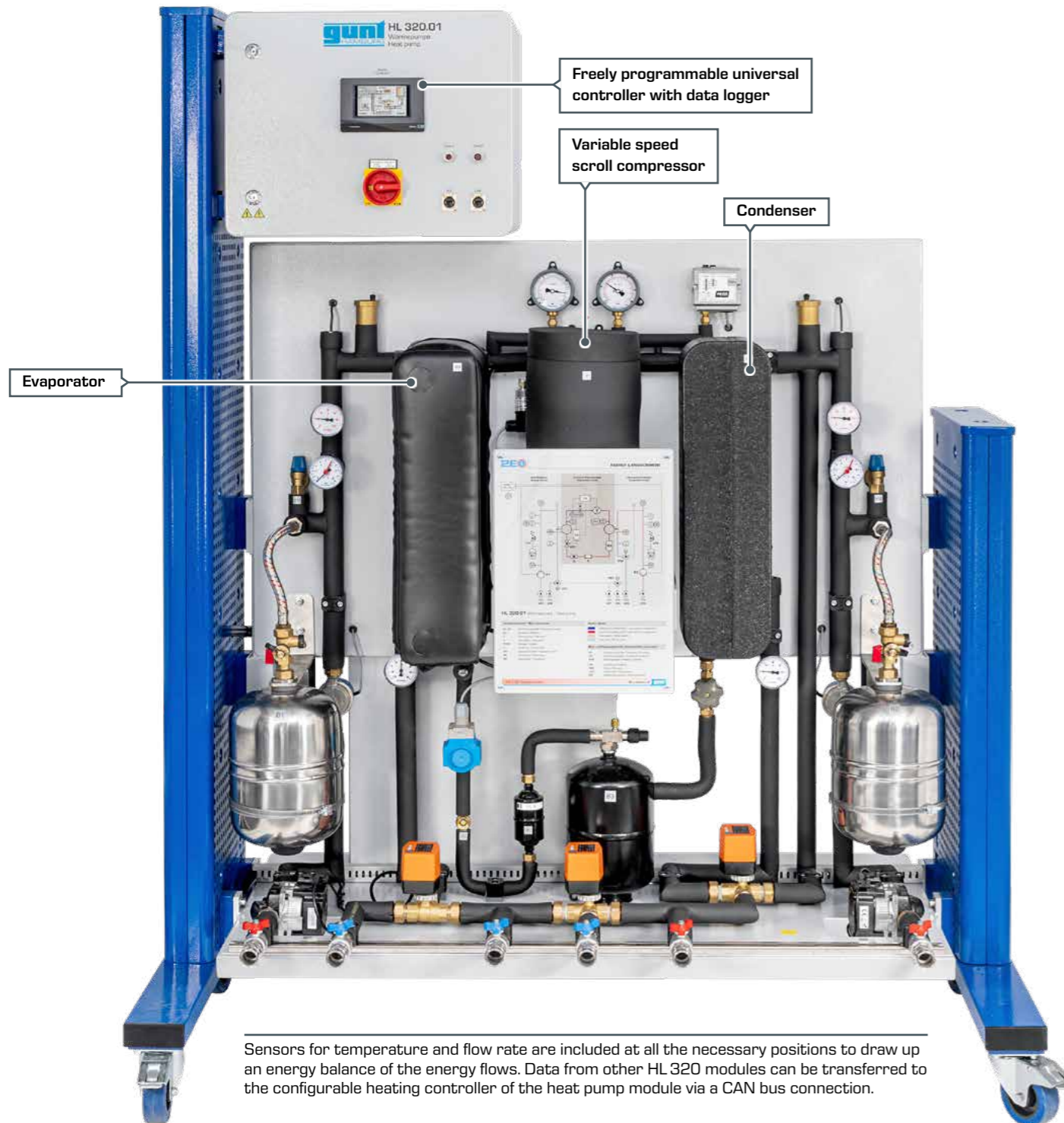

Sensors for temperature and flow rate are included at all the necessary positions to draw up an energy balance of the energy flows. Data from other HL 320 modules can be transferred to the configurable heating controller of the heat pump module via a CAN bus connection.

The HL 320.01 Heat pump is part of the HL 320 modular system and provides you with a variety of combination options from geothermal and solar thermal energy in a modern heating system. The heat pump is driven by a variable speed scroll compressor.

This means it is possible to adapt the heating power of the heat pump to the current heating system demand.

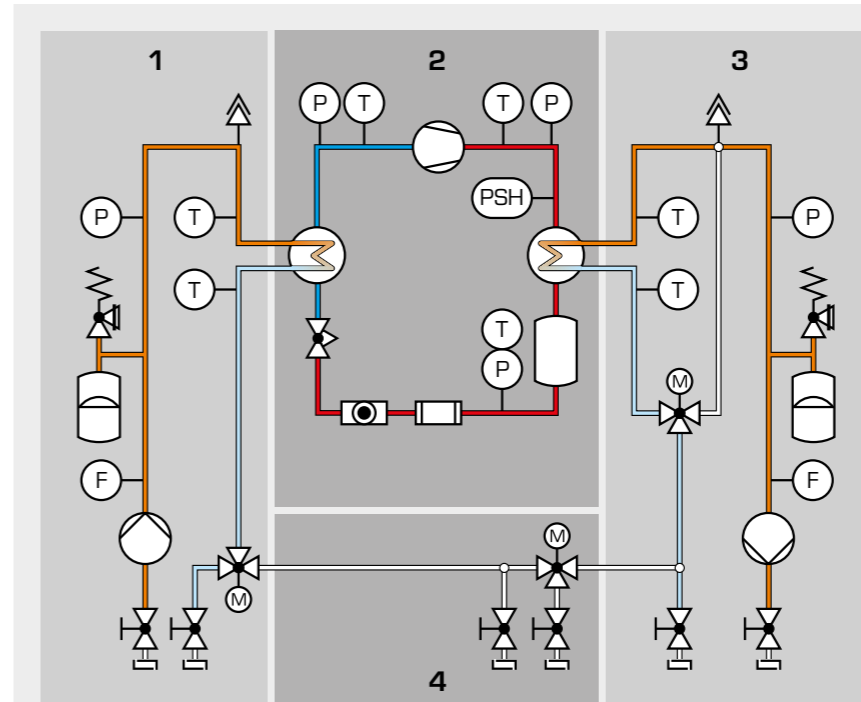

Process schematic of the HL 320.01 Heat pump module

- 1 source circuit connections, 2 refrigeration circuit, 3 heating circuit connections, 4 additional options for including HL 320 modules;
- hot heat transfer fluid,
- cold heat transfer fluid,
- refridgerant, high pressure,
- refridgerant, low pressure



Fixed and movable spirals of a scroll compressor

In combination 3 of the HL 320 system, the following modules are combined to create one system:

- HL 320.01 Heat pump
- HL 320.07 Underfloor heating/geothermal energy absorber
- HL 320.08 Fan heater/air heat exchanger

This combination allows fundamental experiments on the operating behaviour of the heat pump. For more detailed experiments a storage module (HL 320.05) and a thermal solar collector, for example, can be connected.

Learning objectives

- function and design of a heat pump
- distinguishing different operating conditions
- factors influencing the COP (coefficient of performance)
- parameterisation of a heat pump controller

HL 320.02 Conventional heating

In heating systems using different renewable heat sources, it may be economically feasible to cover the peak demand by means of a conventional heater. In order to be able to investigate this aspect in the HL 320 modular system, the HL 320.02 module provides an additional heater that can easily be integrated into different system configurations.

The practical cost of operating this heater for your experiments remains low because an electrically operated heating element is used. The heating element is inserted into the storage tank of the HL 320.05 Central storage module and can be controlled by the storage module's controller via CAN bus. An integrated meter records the amount of electricity consumed. The data from this meter can be sent to the controller of the HL 320.05 Central storage module via the CAN bus connection for capture by a data logger.

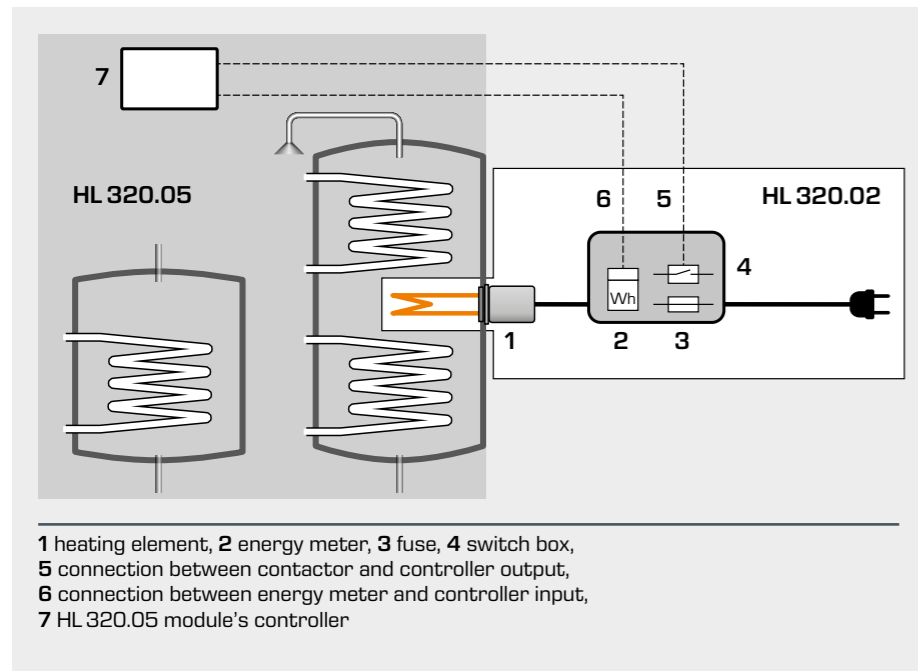

About the product:



The storage tank is emptied in preparation for the experiment. The auxiliary heater can easily be inserted subsequently in just a few steps.

Learning objectives

- complementary heating and/or domestic water heating by conventional additional heater
- bivalence point and heating load
- control strategies for complementary heating

HL 320.03 Flat collector

In conjunction with other HL 320 modules, you can conduct experiments on solar thermal energy domestic water heating with the HL 320.03 Flat collector. The control engineering for the combined production of domestic hot water and heating is of particular practical relevance. Here, the system is controlled and data captured via CAN bus via the HL 320.05 Central storage module.

Modules are easily connected via hoses and quick-release couplings. Different combinations for renewable heat sources can be tested and optimised in conjunction with other modules from the HL 320 system.

About the product:



Learning objectives

- determining the net power
- how temperature, illuminance and angle of incidence affect the collector efficiency
- integration of a flat collector in a modern heating system
- hydraulic and control engineering operating conditions
- energy balances
- optimisation of operating conditions for different types of use

HL 320.04 Evacuated tube collector

The HL 320.04 unit provides you with an evacuated tube collector in a modern design. Evacuated tube collectors reach much higher operating temperatures compared to simple flat collectors due to the lower thermal losses. In practice, evacuated tube collectors are used where there is limited floor space, for example. In the year-round heating operation, evacuated tube collectors enable the reduction of the seasonal demand on a conventional auxiliary heater. HL 320.04 is one of the modules

from the HL 320 Solar thermal energy and heat pump modular system. The experiment module can be incorporated into the modular system in a variety of different ways. The module can be used both for generating heated domestic water and for the combined production of domestic hot water and for heating rooms. Pipe connections for the heat transfer fluid are easy to create and alter thanks to the quick-release couplings.

About the product:

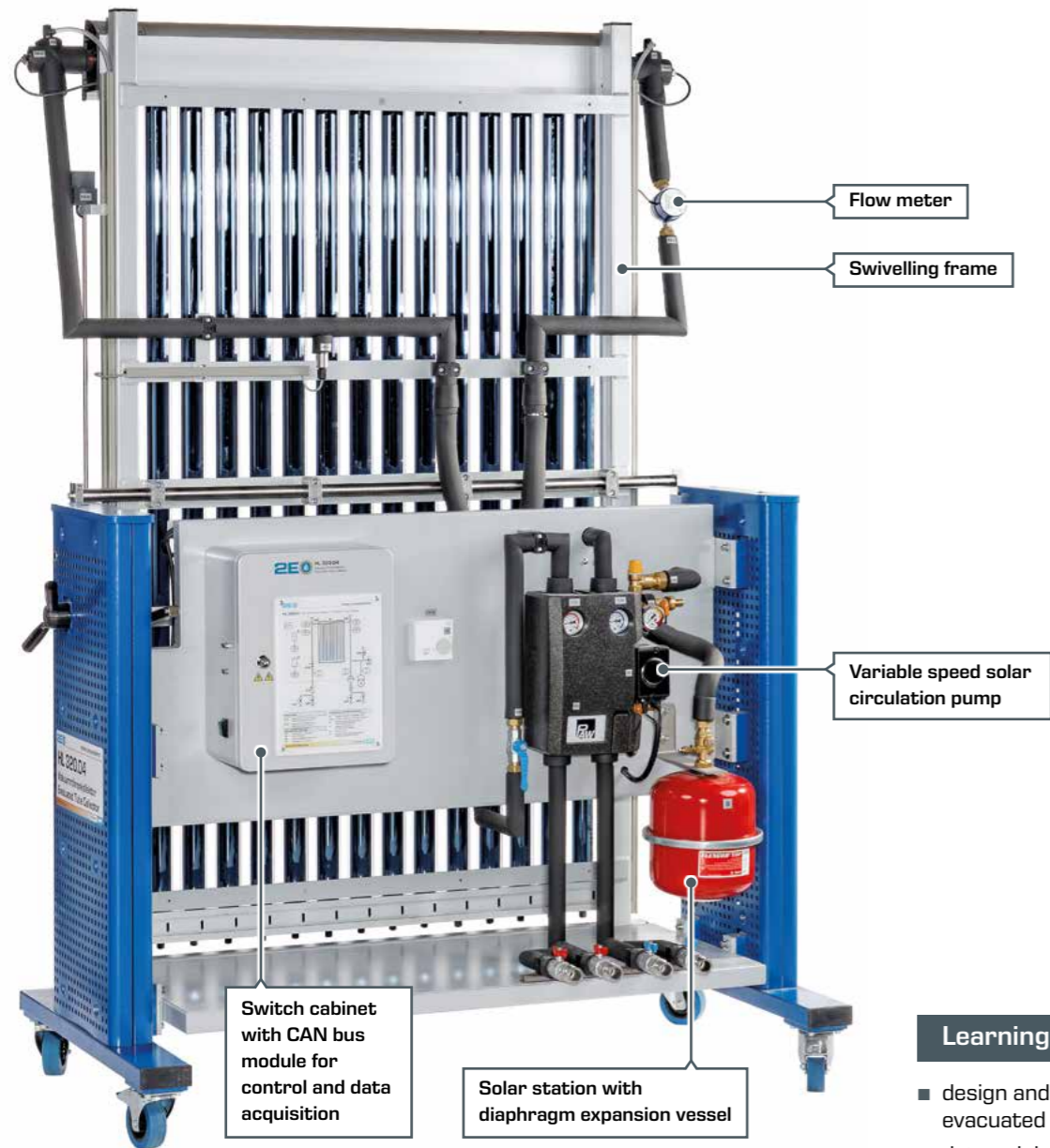

Learning objectives

- design and operation of an evacuated tube collector
- determining the net power and parameters affecting collector efficiency
- integration of an evacuated tube collector in a modern heating system

HL 320.05 Central storage module with controller

The HL 320.05 Central storage module with controller has been developed for your experiments as a central component of the HL 320 modular system. HL 320.05 contains two different heat storage systems, pipes, a pump, two motorised 3-way valves and safety devices. Quick-release couplings on the front of the module enable hydraulic connections to other modules

in the modular system. In addition, HL 320.05 contains a freely-programmable heating controller, which is connected to the respective modules via control and data lines (CAN bus). This controller allows you to operate and study all intended module combinations.

About the product:



HL 320.07 Underfloor heating / geothermal energy absorber

Underfloor heating systems transfer heat through piping systems arranged in a spiral or winding pattern underneath the floor covering. Underfloor heating requires much lower feed flow temperature than conventional radiators. Besides its function as a heat sink when used as an underfloor heating system, HL 320.07 can also be used as a heat source for a heat pump in the HL 320 modular system. In this case, the direction of the heat transport is reversed. HL 320.07 is equipped with three separately selectable piping systems of different lengths. The pipes are surrounded by a tank which can be filled with water.

Sensors are mounted on the piping system to detect the temperatures in the feed and return. Heat quantities and energy balances can be calculated using these temperatures together with the measurement data from the integrated flow meter. Data is transferred to the controller of each main module (HL 320.01 or HL 320.05) via the CAN bus connection. The integrated 3-way mixing valve can also be controlled by the controller via the CAN bus connection.

About the product:



Learning objectives

- energy balance in combined heating systems for domestic hot water generation and heating
- heat transfer in an underfloor heating system
- use of heat sources for heat pump systems

HL 320.08 Fan heater / air heat exchanger

When heating rooms, fan heaters offer the possibility of achieving a comparatively good transfer of heat to the room air compared to traditional heating radiators, even at small dimensions. When combined with a heat pump, the fan heater often represents a beneficial application both economically and in terms of energy, especially when renovating heating systems in old buildings. The HL 320.08 experiment module completes your HL 320 modular system.

This module can also be operated as either a heat sink or a heat source for a heat pump. Sensors for temperature and flow rate are available to create energy balances. Data is transferred to the controller of each main module (HL 320.01 or HL 320.05) via the CAN bus connection.

About the product:



Learning objectives

- how the temperature difference between the heating feed and return affects the overall efficiency of a heating system
- operating conditions when used as an air heat exchanger in a heat pump system
- comparison of an air heat exchanger with other heat sources in a heat pump system

The complete GUNT programme



Engineering mechanics and engineering design

- statics
- strength of materials
- dynamics
- machine dynamics
- engineering design
- materials testing

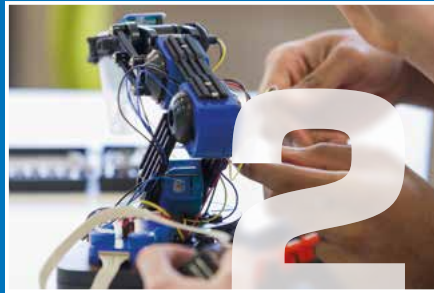

Mechatronics

- engineering drawing
- cutaway models
- dimensional metrology
- fasteners and machine parts
- manufacturing engineering
- assembly projects
- maintenance
- machinery diagnosis
- automation and process control engineering



Thermal engineering

- fundamentals of thermodynamics
- heat exchangers
- thermal fluid energy machines
- internal combustion engines
- refrigeration
- HVAC



Fluid mechanics

- steady flow
- transient flow
- flow around bodies
- components in piping systems and plant design
- turbomachines
- positive displacement machines
- hydraulic engineering



Process engineering

- mechanical process engineering
- thermal process engineering
- chemical process engineering
- biological process engineering
- water treatment



2E Energy & Environment

- | Energy | Environment |
|----------------------------------|-------------|
| ■ solar energy | ■ water |
| ■ hydropower and ocean energy | ■ air |
| ■ wind power | ■ soil |
| ■ biomass | ■ waste |
| ■ geothermal energy | |
| ■ energy systems | |
| ■ energy efficiency in buildings | |

Contact

G.U.N.T. Gerätebau GmbH
Hanskampring 15-17
22885 Barsbuettel
Germany

+49 40670854-0
sales@gunt.de
www.gunt.de



Visit our website
www.gunt.de