

RT 634

Pressure control demonstration unit



Learning objectives/experiments

- fundamentals of control engineering
- latest industrial control engineering components: controllers, transducers, actuators
- operation and parameter setting of a multifunctional state-of-the-art digital controller: e.g. parameter setting as P, PI and PID controller
- investigation of disturbance and control response
- influence of different controller parameters on stability and control quality
- investigation of the properties of the open and closed control loop
- processing of process variables using external equipment, e.g. plotter or oscilloscope
- together with accessory RT 650.40: familiarisation with and use of I&C software

Description

- **experimental introduction to control engineering using an example of pressure control**
- **construction of the system with components commonly used in industry**
- **digital controller with freely selectable parameters: P, I, D and all combinations**
- **Optional I&C software RT 650.40 via USB**

This experimental unit provides a comprehensive experimental introduction to the fundamentals of control engineering using an example of pressure control.

All components are clearly laid out on a vertical front panel. The large-format process schematic provides an aid to understanding.

The controlled system is operated by compressed air, which must be provided by the laboratory. The use of two in-line pressure vessels permits a 2nd order controlled system to be constructed. Disturbance variables can be generated by alternate air tapping by way of a hand-operated valve. Both pressure vessels are fitted with manometers. A pressure sensor is installed in the second pressure vessel as measuring element, which detects the pressure as the controlled variable. The controller used is a state-of-the-art digital industrial controller. The actuator in the control loop is an electro-pneumatic control valve. The controlled variable X and the manipulating variable Y can be tapped as analogue signals at lab jacks. This enables external recording equipment, such as a plotter or an oscilloscope, to be connected.

An instrumentation and control software (RT 650.40) with interface module (USB) is available as an accessory. This enables the key process variables to be represented, and control functions executed.

RT 634

Pressure control demonstration unit

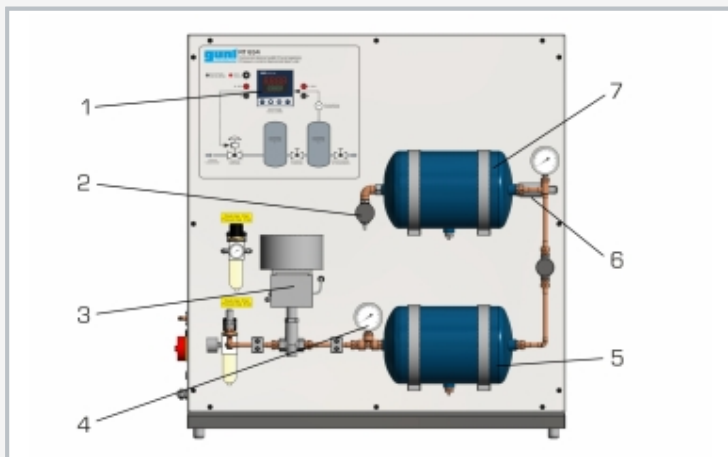

1 controller, 2 needle valve with sound absorber for air tapping, 3 control valve, 4 manometer, 5 pressure vessel, 6 pressure sensor, 7 pressure vessel

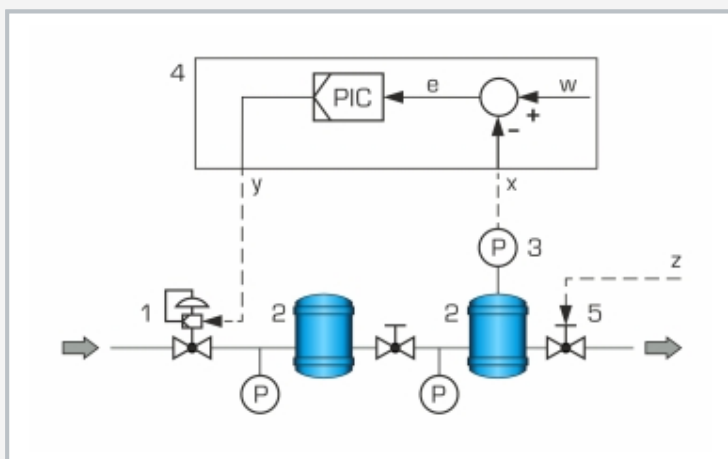

1 actuator: control valve, 2 controlled system: pressure vessel, 3 measuring element: pressure sensor, 4 digital industrial controller, 5 generate disturbance variables via needle valve;

x controlled variable: pressure, y manipulated variable: degree of opening of control valve that directly affects the compressed air supply, z disturbance variable: opening degree of needle valve, w reference variable: input values, e control deviation, P pressure

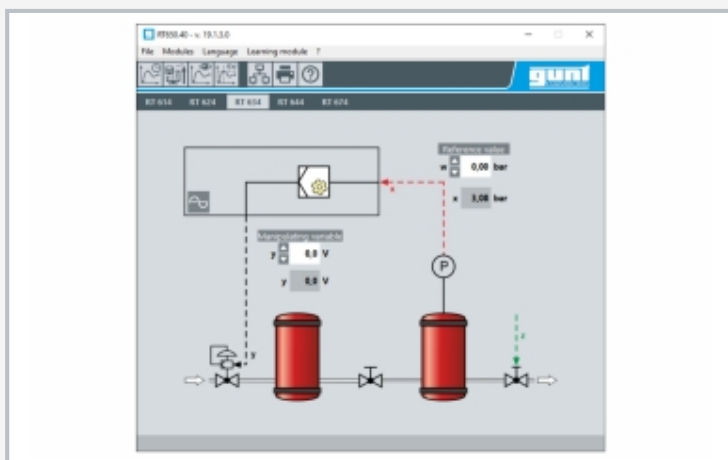

Screenshot of optional I&C software RT 650.40

Specification

- [1] pressure control with components commonly used in industry
- [2] controlled system: two in-line pressure vessels for investigation of a second order controlled system
- [3] measuring element: pressure sensor in the second vessel
- [4] 2 manometers
- [5] digital industrial controller, parameterisable as a P, PI or PID controller
- [6] generation of disturbance variables by needle valve
- [7] actuator: electro-pneumatic control valve
- [8] process variables X and Y accessible as analogue signals via lab jacks
- [9] large process schematic on front panel

Technical data

Operating pressure: 6bar

Pressure vessels

- capacity: 10L
- pressure: max. 10bar

Pressure sensor: 0...6bar

2x manometers: 0...10bar

Electro-pneumatic control valve

- reference variable: 0...10V
- nominal valve stroke: 6mm

Controller: parameterisable as P, PI or PID controller

Process variables as analogue signals: 0...10V

Connection of external recording devices (e.g. oscilloscope, line recorder) via lab jacks

230V, 50Hz, 1 phase

230V, 60Hz, 1 phase

120V, 60Hz, 1 phase

UL/CSA optional

LxWxH: 1000x500x1070mm

Weight: approx. 57kg

Required for operation

Compressed air connection: 7...10bar

Scope of delivery

- 1 experimental unit
- 1 set of laboratory cables
- 1 set of instructional material

RT 634

Pressure control demonstration unit

Optional accessories

WP 300.09

Laboratory trolley

RT 650.40

I&C software for RT 614 - RT 674 series