

ET 210

Fundamentals of wind power plants

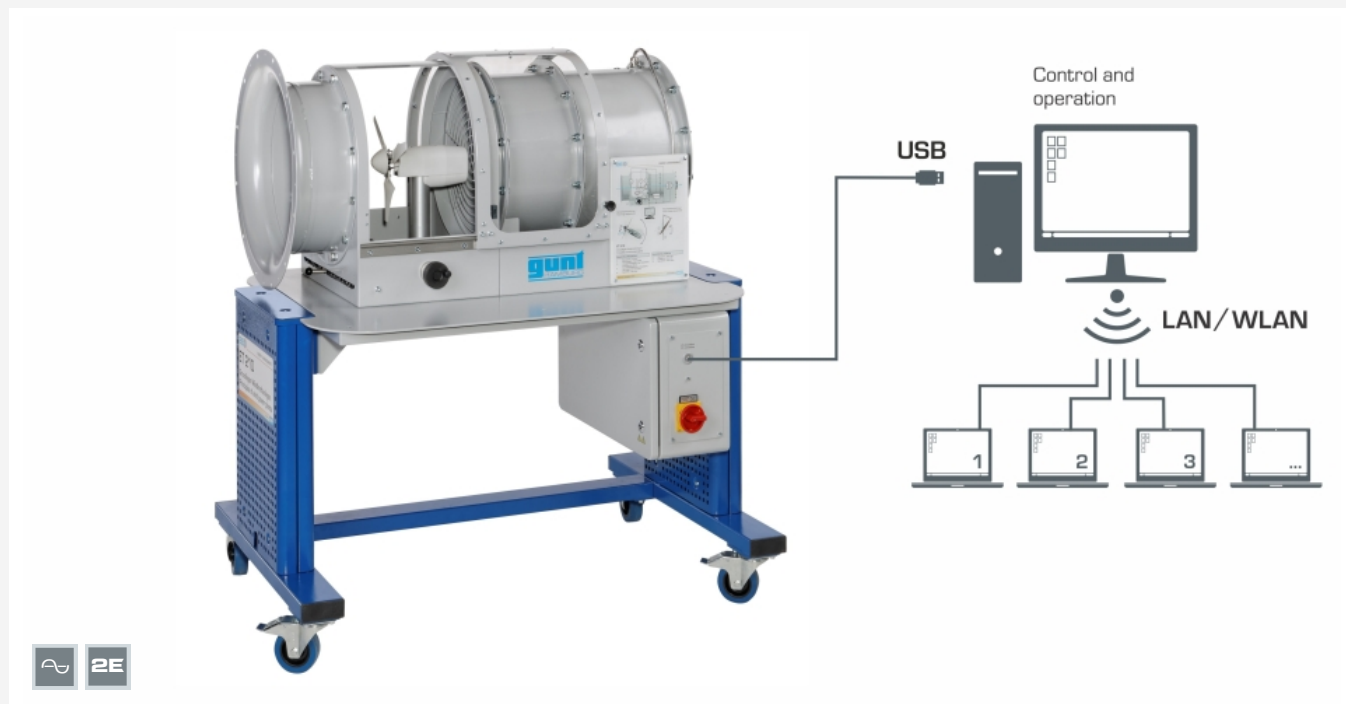

Network capable GUNT software: control and operation via 1 PC. Observation, acquisition, analysis of the experiments at any number of workstations via the customer's own LAN/WLAN network.

Description

- **wind power plant with variable speed**
- **adjustment of rotor blade and yaw angle**
- **network capability: observe, acquire, analyse experiments via customer's own network**

In modern wind power plants, the power output from the wind is adapted to the changing wind conditions. In the strong wind range, power output is limited to protect the turbine. The rotor blade adjustment serves this purpose. By adjusting the angle, this changes the forces acting on the rotor blade. In the normal wind range, power consumption is optimised by means of generator systems with variable speed.

ET 210 demonstrates a wind power plant with rotor blade adjustment and generator with variable speed. The wind power plant stands on a tower in a wind tunnel. The air flow is generated by an adjustable speed fan. A flow straightener ensures consistent and low-turbulence flow. A three-blade rotor drives the generator directly.

In order to approach different operating points, the target speed of the rotor can be set. A servomotor is used to change the adjustment angle of the rotor

blades. The angle between the rotor axis and the wind direction (yaw angle) can be adjusted by means of a handwheel.

The rotor speed is precisely measured by Hall sensors built into the generator. The wind velocity is measured by a horizontally adjustable wind velocity sensor, so that the average wind velocity over the rotor surface can be recorded. The yaw angle is measured by an angle sensor. The operation and control of the experimental unit is carried out via a PC (not included in the scope of delivery) with GUNT software connected via a USB interface. The network capable GUNT software makes it possible to observe, acquire, and analyse the experiments at any number of workstations via the customer's own network with just one licence. The GUNT software calculates the converted electrical power, the generator torque and system-specific parameters.

The rotor blades can be easily replaced. The wind tunnel is closed during the experiments to ensure that the experiments are conducted safely. The interlock on the transparent protective cover and a smart shut down system that turns off the wind tunnel fan in the event that over current or over speed is detected, ensure safe operation.

Learning objectives/experiments

- conversion of kinetic energy into electrical energy
- power adjustment by means of
 - ▶ speed adjustment
 - ▶ rotor blade adjustment
- behaviour in the case of oblique flow
- recording of characteristic diagrams
- determination of the power coefficient
 - ▶ as a function of the tip-speed ratio and rotor blade adjustment angle
 - ▶ as a function of the tip-speed ratio and yaw angle
- comparison of different rotor blade shapes
- GUNT E-Learning
 - ▶ multi-media online course on the fundamentals of wind power
 - ▶ learning independent of time and place
 - ▶ access via Internet browser
 - ▶ check through targeted review of the learning objectives

ET 210

Fundamentals of wind power plants



1 inlet contour, 2 experimental section, 3 wind tunnel, 4 switch box

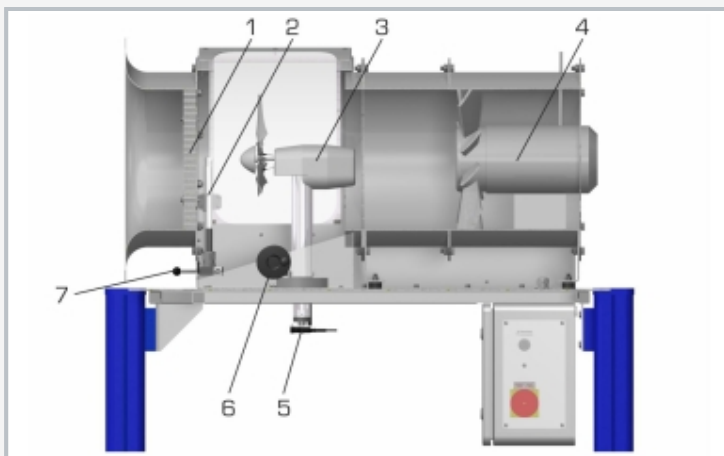

1 flow straightener, 2 wind velocity sensor, 3 wind power plant, 4 fan, 5 yaw angle sensor, 6 handwheel, 7 lever

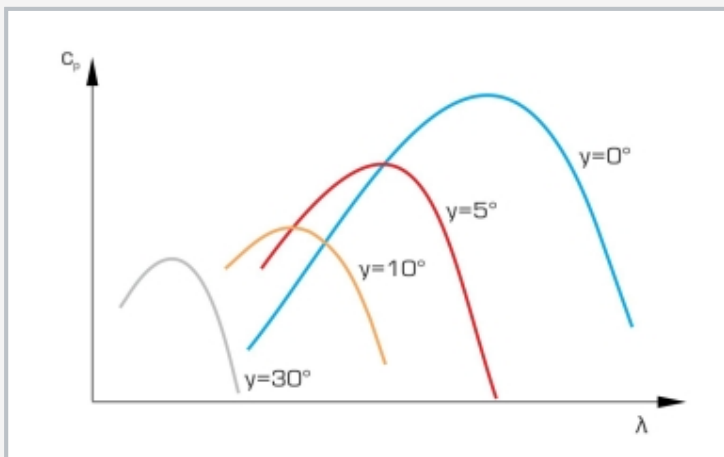

Power coefficient via tip-speed ratio at different rotor blade angles and constant wind velocity

Specification

- [1] wind power plant with adjustment of rotor blade and yaw angle adjustment
- [2] remote learning: detailed E-Learning course on the basics of wind power accessible online
- [3] gearless wind power plant with 3-blade rotor
- [4] generator system with variable speed
- [5] power regulation by means of rotor blade adjustment
- [6] interchangeable rotor blades
- [7] fan with adjustable speed generates required air flow
- [8] wind velocity, rotor speed and yaw angle are measured by sensors
- [9] control and operation via PC with GUNT software and by control elements of the experimental unit
- [10] safety features: interlock on the door, smart shut down system
- [11] network capability: observe, acquire, analyse experiments at any number of workstations with GUNT software via the customer's own LAN/WLAN network
- [12] GUNT software via USB under Windows 11

Technical data

Wind power plant

- \varnothing rotor: 0,3m
- number of rotor blades: 3
- rated electrical power: approx. 12W
- rated wind velocity: 10m/s
- rated speed: 2865min⁻¹
- designed tip-speed ratio: 4,5
- rotor blade adjustment: -5...35°
- weight: approx. 1,6kg
- nacelle: LxWxH: approx. 270x65x90mm

Generator

- rated voltage: 24V
- rated current: 2,52A

Rotor blades

- 3x straight rotor blade profile
- 3x optimised rotor blade profile

Wind tunnel: \varnothing 400mm

Axial fan

- max. volumetric flow rate: 6860m³/h
- max. power consumption: 1,1kW

Measuring ranges

- wind velocity: 1...15m/s
- speed: 0...4000min⁻¹
- current: $\pm 2,02A$
- yaw angle: $\pm 40^\circ$

230V, 50Hz, 1 phase; 230V, 60Hz, 1 phase

120V, 60Hz, 1 phase; UL/CSA optional

LxWxH: 1240x800x1330mm; Weight: approx. 143kg

Required for operation

PC with Windows

Scope of delivery

- 1 experimental unit, 1 GUNT software + USB cable
- 1 set of accessories, 1 set of instructional material