

ET 165

Refrigeration system with open compressor



The illustration shows a similar unit

Description

- capacity measurement at the open compressor with variable speed
- refrigeration chamber with adjustable cooling load
- part of the GUNT FEMLine
- dynamic recording of the refrigerant mass flow rate

ET 165 enables basic experiments in the field of refrigeration. The trainer includes a closed refrigeration circuit with open compressor, a condenser with fan, a thermostatic expansion valve and an evaporator in a refrigeration chamber with transparent door. A fan in the refrigeration chamber ensures an even temperature distribution. A cooling load is simulated by an adjustable heater in the refrigeration chamber.

The drive unit HM 365 drives the compressor via a V-belt. The compressor speed is set at the HM 365. The circuit is equipped with a combined pressure switch for the delivery and intake side of the compressor.

All relevant measured values are recorded by sensors. Digital displays indicate the measured values. The GUNT software provides exact data on the condition of the refrigerant, which is used to calculate the refrigerant mass flow rate accurately. The calculation therefore gives a much more accurate result than measurement using conventional methods. The simultaneous transmission of the measured values to a data recording software enables convenient analysis and the representation of the process in the log p-h diagram. The software also displays the important characteristic variables of the process, such as the refrigeration capacity and the coefficient of performance.

Learning objectives/experiments

- fundamentals of refrigeration
- design and components of a refrigeration system
 - ▶ open compressor with drive
 - ▶ condenser
 - ▶ evaporator
 - ▶ thermostatic expansion valve
 - ▶ pressure switch
- determination of important characteristic variables
 - ▶ coefficient of performance
 - ▶ compressor capacity
 - ▶ refrigeration capacity
 - ▶ compression ratio
 - ▶ volumetric efficiency
- representation of the thermodynamic cycle in the log p-h diagram
- determination of the compressor efficiency
- effect of the compressor flow rate on the refrigeration circuit

ET 165

Refrigeration system with open compressor

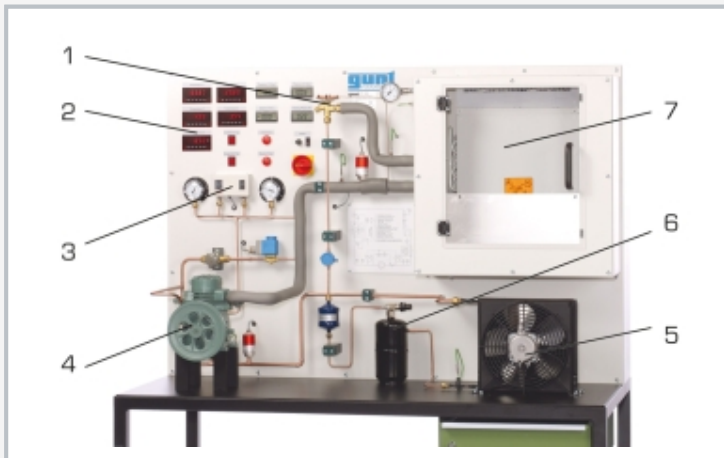

1 expansion valve, 2 displays and controls, 3 pressure switch, 4 compressor, 5 condenser, 6 receiver, 7 refrigeration chamber

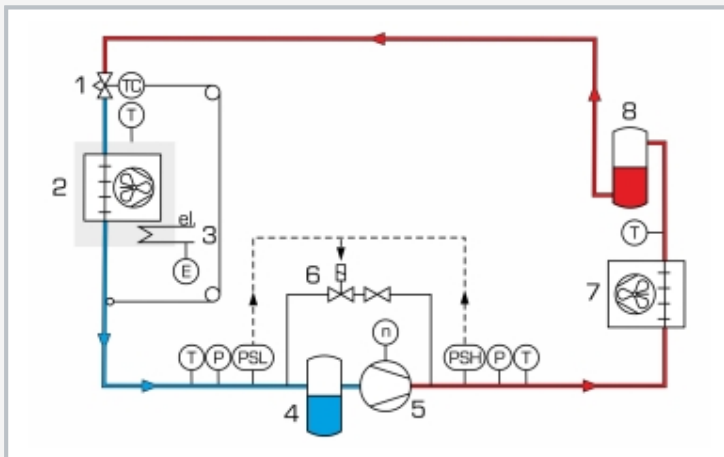

1 expansion valve, 2 refrigeration chamber, 3 heater, 4 liquid separator, 5 compressor with connection to the HM 365, 6 solenoid valve, 7 condenser, 8 receiver; T temperature, P pressure, PSL, PSH pressure switch, n speed, E electric power; blue: low pressure, red: high pressure

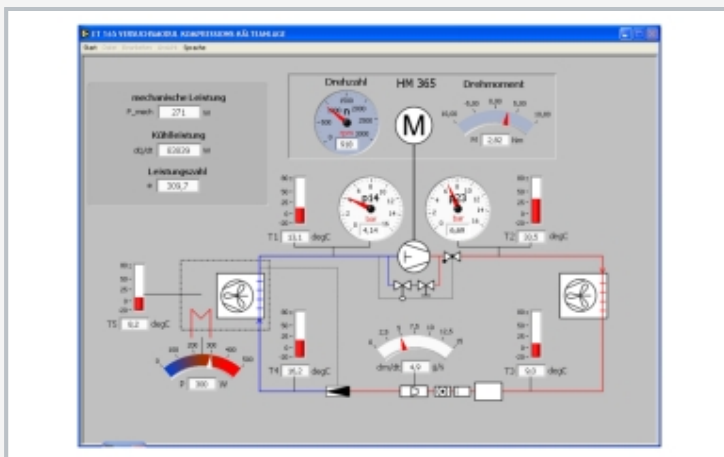

Software screenshot: process schematic

Specification

- [1] investigation of a refrigeration circuit with speed-controlled compressor
- [2] refrigeration circuit with open compressor, condenser, thermostatic expansion valve and evaporator in refrigeration chamber
- [3] cooling load in the refrigeration chamber adjustable via heater
- [4] drive and speed adjustment of the open compressor via HM 365
- [5] condenser and evaporator with fan
- [6] pressure switch to protect the compressor
- [7] sensors for pressure, temperature, power and speed
- [8] refrigerant mass flow rate precisely calculated via GUNT software
- [9] GUNT software for data acquisition via USB under Windows 10
- [10] refrigerant R513A, GWP: 631

Technical data

Open compressor

- refrigeration capacity: approx. 965W (at speed: 1450min⁻¹ and 5/40°C)

Condenser with fan transfer area: 2,5m²

- capacity: approx. 1935W at 25°C air temperature (ambient) / Δt=15°C

Evaporator

- transfer area: 3,62m²

- capacity: 460W at 3°C air temperature (chamber) / Δt=13°C

Heater power: 500W

Refrigerant: R513A

- GWP: 631

- filling volume: 1,7kg

- CO₂-equivalent: 1,1t

Measuring ranges

- temperature: 4x -5...105°C, 1x -50...250°C

- pressure: -1...15bar, -1...24bar

- speed: 0...1000min⁻¹

- mass flow rate: refrigerant, calculated 0...17kg/h

- power: 0...500W

230V, 50Hz, 1 phase

230V, 60Hz, 1 phase

120V, 60Hz, 1 phase

UL/CSA optional

LxWxH: 1470x800x1850mm

Weight: approx. 185kg

Required for operation

PC with Windows recommended

Scope of delivery

- 1 trainer
- 1 V-belt
- 1 GUNT software + USB cable
- 1 set of instructional material

ET 165

Refrigeration system with open compressor

Required accessories

HM 365 Universal drive and brake unit

Optional accessories

for Remote Learning

GU 100 Web Access Box

with

ET 165W Web Access Software