

RT 454

Temperature control



Control and operation via touch screen or a PC with GUNT software. Observation and analysis of the experiments at any number of workstations via LAN/WLAN.

Description

- digital control of the temperature via PLC
- integrated touch screen or PC with GUNT software as HMI
- network capable GUNT software with data acquisition for remote learning
- use of smart sensors, configuration via PLC: change, save and transfer parameters during operation

The RT 451 – 455 series is constructed entirely from industrial components in order to teach control engineering in a practical manner. The use of smart sensors lays the foundations for Industry 4.0 applications. Smart sensors provide signal processing in addition to the capture of measured values thanks to integrated evaluation electronics. Besides process data, it is also possible to exchange configuration, diagnostic or statistical data. In practice this makes it faster to change over production lines, for example, or enables predictive maintenance.

The RT 454 trainer has all components required for an open and closed control loop. The controlled system is a pipe section with temperature measurement at different positions which is passed

through by water. Two integrated selectable process delay pipe sections allow dead times to be represented. The temperature as the controlled variable can optionally be recorded by one of the three smart temperature sensors. The actuator in the control loop is a heater and/or a heat exchanger with fan as a cooling unit. The control response with switching or continuous control is investigated. The heater can be operated continuously or switching, the fan is operated switching or manually. Defined disturbance variables can be generated by means of a ball valve with motor drive.

The smart temperature sensors have an IO-Link interface for interference-free transfer of measured values and the exchange of configuration data.

The trainer is controlled and operated via the integrated PLC and the touch screen or via GUNT software (external PC required). The control response is displayed in the form of a time function. The network capable software makes it possible to follow and analyse the experiments at any number of workstations via a LAN/WLAN connection to the local network.

Learning objectives/experiments

- design and function of a temperature control
- investigate the properties of open and closed loops
- control response in
 - ▶ continuous control
 - ▶ two-point control
 - ▶ three-point control
 - ▶ dead times
- investigate the influence of the temperature sensor position on the properties of the controlled system
- investigate disturbance and reference variable response
- familiarisation with industrial control engineering components: Siemens PLC as digital controller, smart temperature sensor with IO-Link interface as measuring element, heater and cooling unit as actuators
- familiarisation with IO-Link as communications interface for smart sensors
 - ▶ standardised, open technology
 - ▶ interference-free transfer of measured values
 - ▶ exchange of configuration data
 - ▶ system design (IO-Link device, IO-Link master, PLC)

RT 454

Temperature control



1 cooling unit (air/water heat exchanger with fan), 2 ball valve with motor drive, 3 process delay pipe section, 4 pump, 5 expansion tank, 6 heater, 7 smart temperature sensors, 8 touch screen

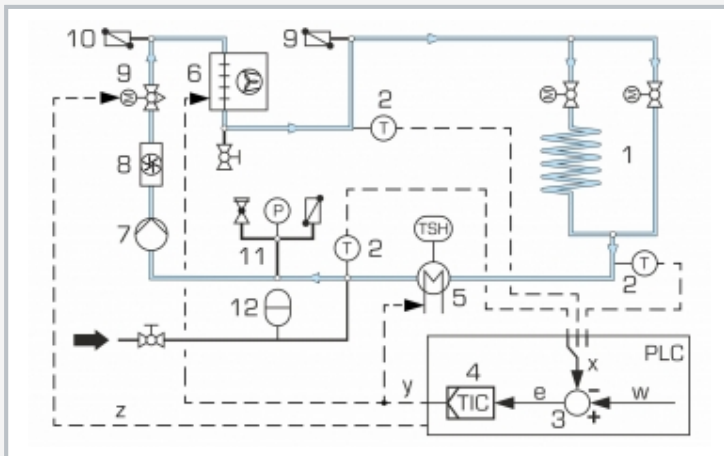

1 controlled system: pipe section with process delay pipe sections, 2 measuring element: smart temperature sensor, 3 comparator: part of the PLC, 4 digital controller integrated into PLC, 5 actuator: heater, 6 actuator: cooling unit, 7 pump, 8 flow rate indicator, 9 generate disturbance variables via ball valve with motor drive, 10 bleed valve, 11 safety group, 12 expansion tank

x controlled variable: temperature, y manipulated variable: control of heater and/or cooling unit, z disturbance variable: degree of opening of ball valve, w reference variable: input values, e control deviation, T temperature, TSH, temperature switch

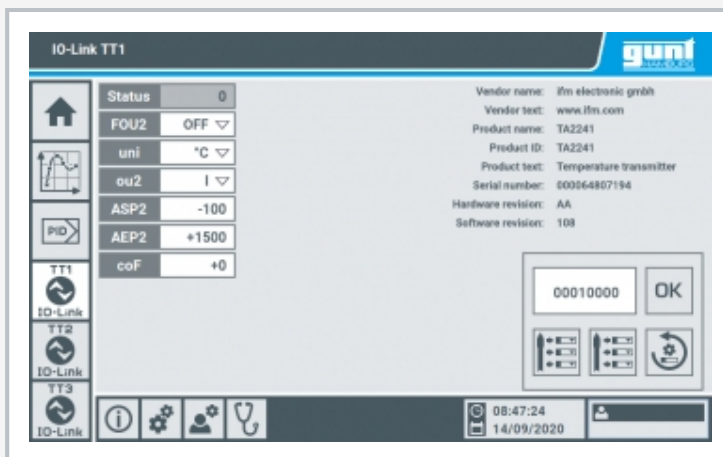

Screenshot from the PLC: configuration of smart temperature sensors via IO-Link

Specification

- [1] temperature control process with standard industrial components and smart sensors
- [2] digital control via PLC, controller can be parametrised as P, PI or PID controller as well as switching with hysteresis
- [3] controlled system: pipe section with 2 process delay pipe sections of different lengths
- [4] actuator: screw-in heater with temperature limiter as dry-running protection and air/water heat exchanger with fan as cooling unit
- [5] measuring element: 3 smart temperature sensors with IO-Link interface for interference-free transfer of measured values and exchange of configuration data
- [6] smart temperature sensor configured via PLC
- [7] generate disturbance variables via ball valve with motor drive, operation via PLC
- [8] closed water circuit
- [9] remote learning: follow and analyse experiments at any number of workstations with LAN/WLAN connection via network capable GUNT software
- [10] GUNT software for data acquisition via LAN under Windows 8.1, 10

Technical data

Process delay pipe sections

- straight pipe, length: 0,7m, Ø inner: 20mm
- pipe spiral, length: 16,5m, Ø inner: 10mm

PLC

- type: Siemens SIMATIC S7-1200
- modules: compact CPU (8 DI, 6 DO, 2 AI), analogue I/O module (4 AI, 2 AO), IO-Link master

3 smart temperature sensors

- measuring element: Pt1000
- communications interface: IO-Link

Screw-in heater: 2kW

Fan

- power: 31W
 - max. flow rate: 545m³/h
- Pump
- max. flow rate: 5,0m³/h, max. head: 6m

Measuring ranges

- temperature: 3x -10...150°C
- opening degree: 0...100%

230V, 50Hz, 1 phase; 230V, 60Hz, 1 phase

120V, 60Hz, 1 phase; UL/CSA optional

LxWxH: 2030x790x1987mm

Weight: approx. 204kg

Required for operation

PC with Windows recommended

Scope of delivery

trainer, 1 GUNT software, 1 set of accessories, 1 set of instructional material