

RT 455

pH value control



Control and operation via touch screen or a PC with GUNT software. Observation and analysis of the experiments at any number of workstations via LAN/WLAN.

Description

- digital control of the pH value via PLC
- integrated touch screen or PC with GUNT software as HMI
- network capable GUNT software with data acquisition for remote learning
- use of smart sensors: sensor calibration via PLC, additional transfer of parameters

The RT 451 – 455 series is constructed entirely from industrial components in order to teach control engineering in a practical manner. The use of smart sensors lays the foundations for Industry 4.0 applications. Smart sensors provide signal processing in addition to the capture of measured values thanks to integrated evaluation electronics. Besides process data, it is also possible to exchange configuration, diagnostic or statistical data. In practice this makes it faster to change over production lines, for example, or enables predictive maintenance.

The RT 455 trainer has all components required for an open and closed control loop. A pipe section, which is passed through by water as a carrier medium, serves as the controlled system. The measuring element is a smart pH sensor, which measures the pH value as

the controlled variable at the outlet of the pipe section. A metering pump for adding alkaline solution and a continuous solenoid valve for varying the mass flow rate are included in the inlet of the pipe section in order to generate disturbance variables. A second smart pH sensor displays the pH values after the alkaline solution is added. A downstream metering pump serves as the actuator, which adds acid for neutralisation. Static mixers ensure the water and the added solutions are thoroughly mixed. The solution that emerges from the pipe section is collected in a product tank. For disposal, accessories are included to manually measure the pH value.

The smart sensors are connected via Modbus, which also makes it possible to calibrate the sensors via the PLC and to transmit parameters.

The trainer is controlled and operated via the integrated PLC and the touch screen or via GUNT software (external PC required). The control response is displayed in the form of a time function. The network capable software makes it possible to follow and analyse the experiments at any number of workstations via a LAN/WLAN connection to the local network.

Learning objectives/experiments

- design and function of a pH control system
- investigate the properties of open and closed loops
- investigate disturbance and reference variable response
- familiarisation with industrial control engineering components: Siemens PLC as digital controller, smart pH sensor as measuring element, metering pump as actuator
- familiarisation with Modbus for connecting smart sensors
 - ▶ open standard
 - ▶ quick data exchange
 - ▶ additional transfer of parameters

RT 455

pH value control



1 smart pH sensors, 2 metering pumps, 3 chemicals tanks, 4 product tank, 5 accessories, 6 touch screen

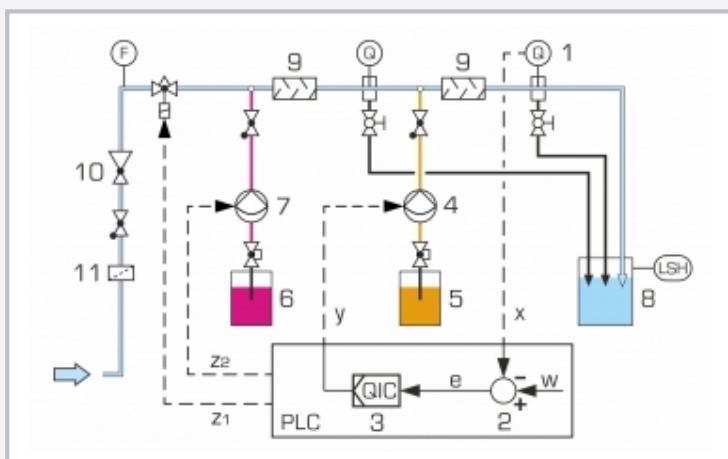

1 measuring element: smart pH sensor, 2 comparator: part of the PLC, 3 digital controller integrated into PLC, 4 actuator: acid metering pump, 5 acid chemical tank, 6 alkaline chemical tank, 7 alkaline metering pump, 8 product tank, 9 static mixer, 10 pressure reducing valve, 11 dirt trap

x controlled variable: pH value, y manipulated variable: speed of acid metering pump, z₁ disturbance variable: degree of opening of solenoid valve, z₂ disturbance variable: speed of alkaline metering pump, w reference variable: input values, e control deviation, F flow rate, G pH value, LSH level switch

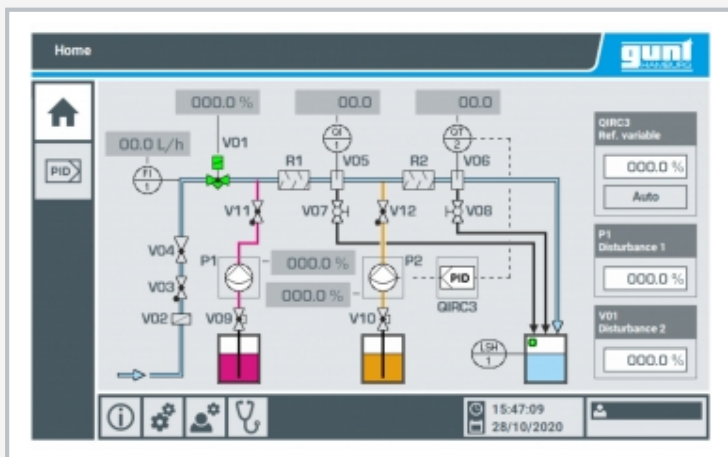

Screenshot PLC: start page with process schematic and all the latest measured values

Specification

- [1] pH control process with standard industrial components and smart sensors
- [2] digital control via PLC, controller can be parametrised as P, PI, or PID controller
- [3] controlled system: corrosion-resistant pipe section
- [4] measuring element: smart pH sensor in transparent measuring tank with overflow
- [5] second smart pH sensor for displaying the pH value after the alkaline solution is added
- [6] smart pH sensors configured and calibrated via PLC
- [7] accessories for pH sensors and for manual pH measurement in the product tank are included
- [8] actuator: metering pump for acid
- [9] generate disturbance variables via metering pump for alkaline solution or continuous solenoid valve in the inlet
- [10] remote learning: follow and analyse experiments at any number of workstations with LAN/WLAN connection via network capable GUNT software
- [11] GUNT software for data acquisition via LAN under Windows 8.1, 10

Technical data

Pipe section: stainless steel
PLC

- type: Siemens SIMATIC S7-1200
- modules: compact CPU (8 DI, 6 DO, 2 AI), communication board, 2 analogue I/O modules (2 AO)

2 smart pH sensors

- with glass shaft and PTFE diaphragm

- integrated Pt1000

- interface: RS-485 Modbus

Metering pumps

- max. flow rate: 2,3L/h each

- max. head: 160m each

Product tank: 20L

Chemicals tanks (HCl, NaOH): 2x 5L

Measuring ranges

flow rate: 2...25L/h

pH value: 2x 0...12 (short-term 14)

230V, 50Hz, 1 phase; 230V, 60Hz, 1 phase

120V, 60Hz, 1 phase; UL/CSA optional

LxWxH: 2030x790x1987mm

Weight: approx. 259kg

Required for operation

water connection, caustic soda NaOH 45%, hydrochloric acid HCl 30%, technically pure

PC with Windows recommended

Scope of delivery

trainer, 1 GUNT software, 1 set of accessories, 1 set of instructional material