

# ET 620

## Air conditioning and ventilation system



### Description

- **complete air conditioning and ventilation system for laboratory operation**
- **high practical relevance due to real dimensions and use of commercial components**
- **manual or automatic operation by PLC air conditioning controller**
- **connection of an external air duct system possible**

The experimental setup represents a real air conditioning and ventilation system. The system capacity is sufficient to climatise a laboratory room.

The air conditioning and ventilation system includes a filter element, a fan with controlled speed, a direct evaporator as air cooler, an electric air heater and humidification by steam humidifier. The following functions are possible: heating / cooling and humidifying / dehumidifying. For this purpose the active components can be run either manually individually or via a central PLC air conditioning controller in automatic operation. The air conditioning controller controls the temperature and air humidity independent of each other. Via time programs, operation is possible dependent on the time of the day or the day of the week, as in reality. Pressure losses can be measured at each section of the duct.

All common components, such as filter, air heater / air cooler, outlets, smoke detector, multi-leaf dampers, inspection and fire protection flaps are available and can be explained. A standard connection piece in the air duct enables the connection to an external air duct system to climatise an existing room.

The air conditioning and ventilation system consists of three independent system components: main unit, steam humidifier and condensing unit. The connection is performed via hoses. Due to the waste heat the condensing unit should not be placed inside the room to be climatized.

### Learning objectives/experiments

- practice-oriented principles of air conditioning and ventilation technology
- design and servicing of an air conditioning and ventilation system
- principles of room air conditioning (h-x diagram)
- explanation of components: filter, air heater, air cooler, humidifier, condensing unit, air conditioning controller, flaps, outlets
- operation of safety devices
- measurement of pressure curve and pressure losses
- effect of air cooler, air heater and humidifier on the state of the air at the outlet
- investigation of the control behaviour of an automatic air conditioning controller, determination of limiting factors

# ET 620

## Air conditioning and ventilation system

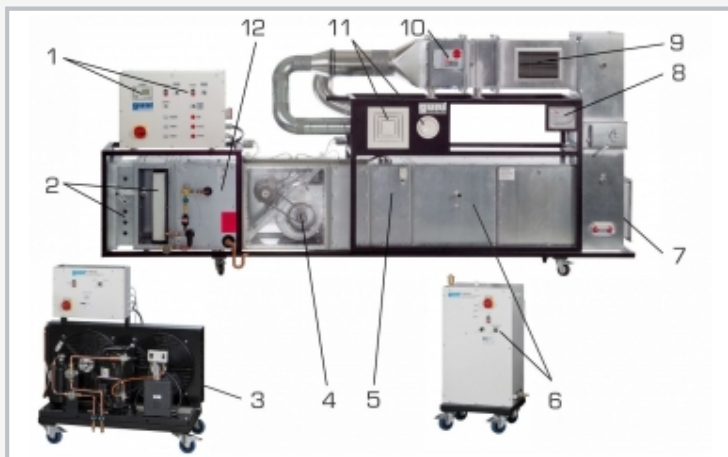

1 switch cabinet with controller, 2 air inlet with filter, 3 condensing unit, 4 fan, 5 air heater, 6 steam humidifier, 7 standard connector to connect an external air duct system, 8 inclined tube manometer, 9 ventilation grille with volume adjustment, 10 fire protection flap, 11 ceiling vents, 12 air cooler (direct evaporator)

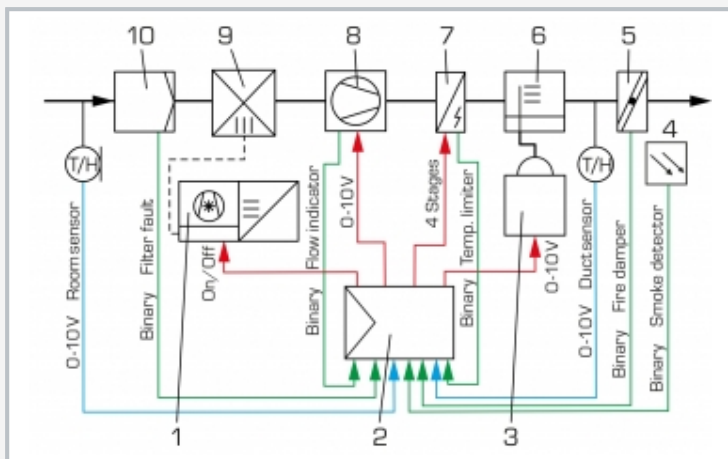

Control schematic: 1 condensing unit, 2 controller, 3 steam humidifier, 4 smoke detector, 5 fire protection flap, 6 humidification section, 7 electric air heater, 8 fan, 9 air cooler (direct evaporator), 10 filter; T/H temperature/humidity

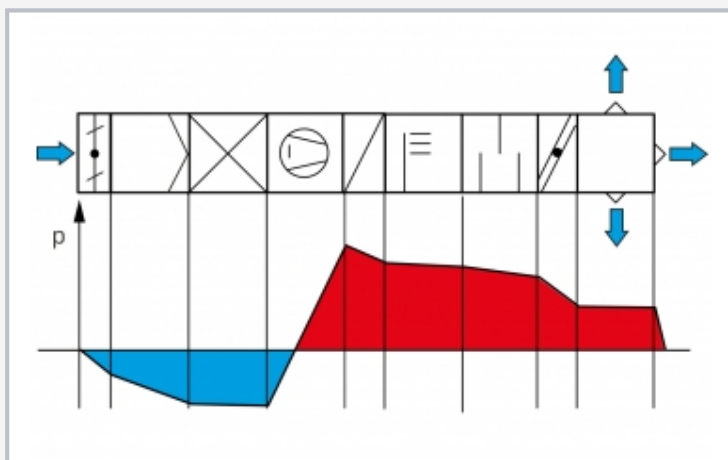

Pressure curve in the system

### Specification

- [1] practice-oriented air conditioning and ventilation system with 3 independent system components: main unit, condensing unit, steam generator
- [2] manual or automatic operation via PLC air conditioning controller
- [3] main unit with air duct, fan, air conditioning system
- [4] air conditioning system with direct evaporator as air cooler, electric air heater, humidification
- [5] hoses connect direct evaporator to condensing unit, humidification system to steam humidifier
- [6] air duct from hot galvanised sheet with sight window and pressure measurement connections to record pressure curves
- [7] air duct with filter, multi-leaf damper, ceiling vent, protective grating, ventilation grille, fire protection flap, inspection flap, sound insulation link, smoke detector
- [8] standard connection piece to connect to external ventilation system
- [9] refrigerant R513A, GWP: 631

### Technical data

- Fan, speed-controlled 0...1500min<sup>-1</sup>
- max. volumetric air flow rate: 2500m<sup>3</sup>/h
  - max. pressure level: 715Pa
  - drive motor power: 1,1kW
- Air heater, 4 stages: 0-5-10-15-20kW
- Air cooler (direct evaporator), cooling capacity: 27kW
- Condensing unit
- rated cooling capacity: approx. 16,6kW at 7.2/32°C
  - power consumption: approx. 7,4kW at 7.2/32°C
- Steam humidifier
- steam capacity: 10kg/h
  - power consumption: 7,5kW
- External standard connection piece: 400x400mm
- Duct cross-sections
- bottom: WxH: 630x630mm, top: WxH: 358x358mm
- Inclined tube manometer: 0...750Pa
- Refrigerant
- R513A
  - GWP: 631
  - filling volume: 11,7kg
  - CO<sub>2</sub>-equivalent: 7,4t
- 400V, 50Hz, 3 phases  
400V, 60Hz, 3 phases; 230V, 60Hz, 3 phases  
UL/CSA optional  
LxWxH: 3870x850x1760mm; 540kg (trainer)  
LxWxH: 1110x740x1120mm; 163kg (condensing unit)  
LxWxH: 510x500x1060mm; 50kg (humidifier)

### Required for operation

water connection, drain

### Scope of delivery

- 1 trainer, 1 condensing unit
- 1 steam humidifier, 1 set of accessories
- 1 set of instructional material