

ET 833

Steam power plant 1,5kW with process control system



The illustration shows the steam power plant together with the cooling tower ET 833.01.

Description

- **complete laboratory-sized steam power plant**
- **process control system based on Ethernet and PLC**
- **plant monitored and controlled via touchscreen control station**

Nowadays large process engineering systems, such as steam power plants, are managed with process control systems (PCS). The entire system is monitored, actuators regulated and controlled, measurements recorded and displayed via the process control system.

The steam power plant ET 833 is specifically designed for training purposes in the field of power plant engineering with process control systems. The system operates very similarly to real large-scale plants due to the high degree of complexity.

An oil-fired once-through steam boiler and a downstream electric superheater generate superheated steam for the single-stage industrial turbine, which is subjected to load via a DC generator. The energy generated is fed back into the grid. The exhaust steam from the turbine is condensed and fed back to the steam boiler.

The feedwater circuit is equipped with a complete water treatment system with ion exchangers and chemical dosing. Sensors capture all relevant parameters. The measured values are both output to the process control system with programmable logic controller and sent to a PC for data acquisition, where they are presented and analysed with GUNT software. Operation of the plant is fully monitored and controlled by the process control system. If necessary, the process control system initiates activation of the corresponding actuators. It is operated via modern touchscreen technology on the control station. A safety system ensures the relevant components are shut-down and error conditions detected in critical operating states.

The experimental plant is built in accordance with statutory safety regulations and includes the mandatory safety facilities. The steam generator is type tested and does not require specific permissions.

The plant can optionally be operated with the cooling tower ET 833.01 or ET 833.02 to supply cooling water.

Learning objectives/experiments

- steam power plant and its components with control and regulation system
- start-up, operation and shut down of a steam power plant
- familiarisation with system control and monitoring via a process control system
- monitoring, servicing and maintenance tasks
- determining: input and output power, component and system efficiency, specific fuel consumption of the system

ET 833

Steam power plant 1,5kW with process control system

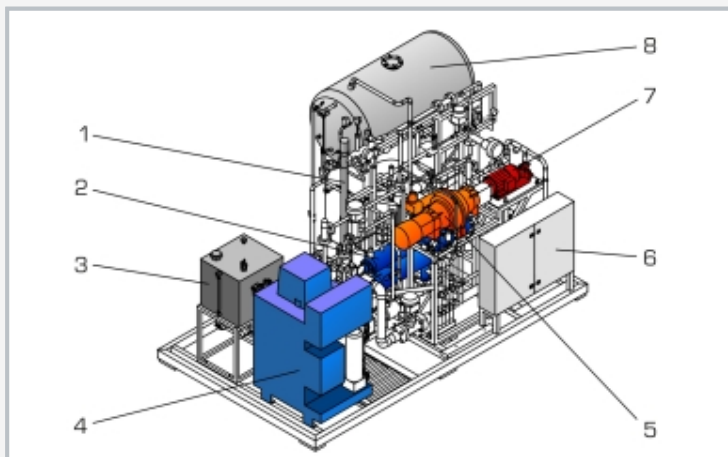

1 superheater, 2 condenser, 3 fuel tank, 4 boiler with switch cabinet, 5 turbine, 6 switch cabinet, 7 generator, 8 feedwater tank with feedwater treatment

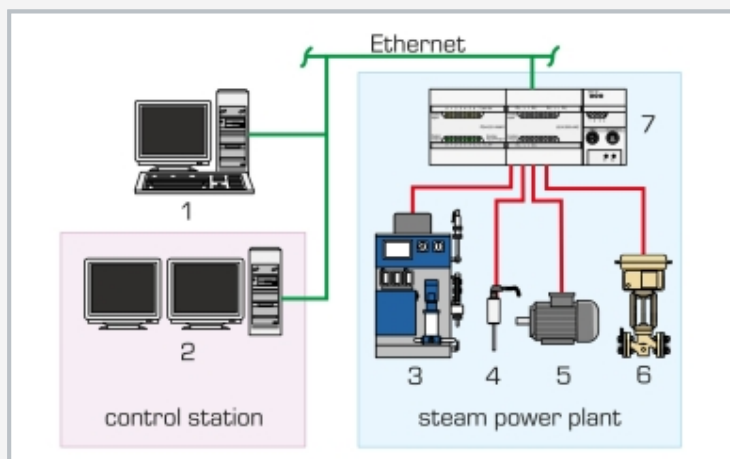

Process control system: 1 data acquisition PC, 2 control PC, 3 steam generator, 4 sensors, 5 pumps/motors, 6 valves, 7 PLC programmable logic controller

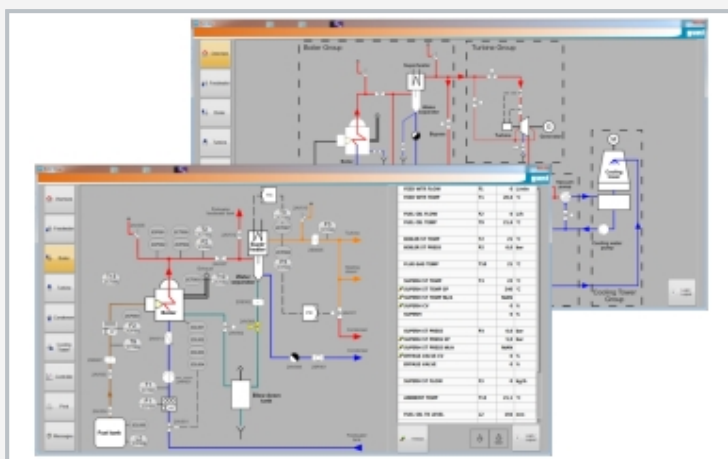

Software screenshot: PCS process control system operated via touchscreen

Specification

- [1] laboratory-sized steam power plant
- [2] oil-fired once-through boiler with electrical superheater
- [3] single-stage industrial steam turbine with DC generator as turbine load
- [4] water-cooled condenser
- [5] feedwater treatment
- [6] process control system for monitoring, control and regulation of the plant
- [7] control station with complete instrumentation on modern LCD monitors, touchscreen operation
- [8] system equipped with sensors and actuators for monitoring and controlling the plant via integrated PLC and Ethernet
- [9] cooling water connection 10m³/h or cooling tower ET 833.01/ET 833.02 required

Technical data

Steam generator

- steam output: 200kg/h at 11 bar
- max. fuel consumption: 12L/h
- heat-up time: 8min
- max. pressure: 13bar

Superheater

- power 7kW

Single-stage axial turbine with Curtis wheel and hydraulic speed regulator

- power: max. 1,5kW at 3000min⁻¹

Water-cooled condenser

- cooling capacity: 98kW
- transfer surface: 2,5m²

Measuring ranges

- temperature: 12x -50...400°C, 1x 0...100°C
- flow rate: 0...167L/min (cooling water)
- pressure: 3x 0...16bar, 2x 0...4bar, 1x -1...1bar
- torque: 0...10Nm
- speed: 0...4000min⁻¹

400V, 50Hz, 3 phases

400V, 60Hz, 3 phases; 230V, 60Hz, 3 phases

LxWxH: 3500x2000x2400mm

Weight: approx. 2250kg

Required for operation

cooling water 10m³/h or ET 833.01/ET 833.02
compressed air connection: 4,5bar, 150L/h

Scope of delivery

- 1 experimental plant
- 1 control station including hardware and software
- 1 set of tools
- 1 set of instructional material

ET 833

Steam power plant 1,5kW with process control system

Optional accessories

061.80550	ET 805.50	Determination of the vapour content for the operation at ambient temperatures above 27°C
061.83301	ET 833.01	Cooling tower 140kW for the operation at ambient temperatures below 27°C
061.83302	ET 833.02	Cooling tower 115kW