

# HL 530

## Training panel function of gas heater



The illustration shows a similar unit.

### Learning objectives/experiments

- familiarisation with the functioning of a combination boiler
- understanding of a heating circuit
- domestic water heating
- measurement of gas pressures on a gas boiler
- determination of power and efficiency

### Description

- **clearly arranged components of a typical combination boiler**
- **separate circuits for room heating and domestic water heating**
- **viewing window for flame observation**
- **additional instrumentation for energy balances**

The HL 530 is used to illustrate the functioning of a gas combination boiler. The main components of the gas boiler are clearly arranged on a panel to allow better understanding. A process schematic also illustrates the function. The HL 530 allows demonstration of a heating circuit and representation of domestic water heating.

A plate heat exchanger is used to simulate a radiator. Cold water is fed through the heat exchanger as a heating load. A viewing window allows observation of the gas flame in the burner. Built-in thermometers and flow meters allow the recording of measured values to determine the power and efficiency. The unit is operated with liquid gas (propane) and is therefore independent of any pre-installed natural gas lines.

# HL 530

## Training panel function of gas heater

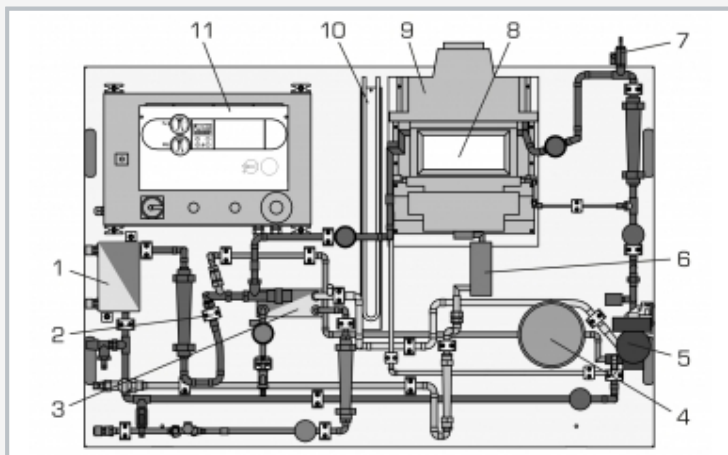

1 plate heat exchanger as radiator, 2 overflow valve, 3 heat exchanger as hot water consumer, 4 expansion vessel, 5 pump, 6 compact fitting, 7 bleed valve, 8 viewing window, 9 burner, 10 U-tube manometer, 11 operating and control unit

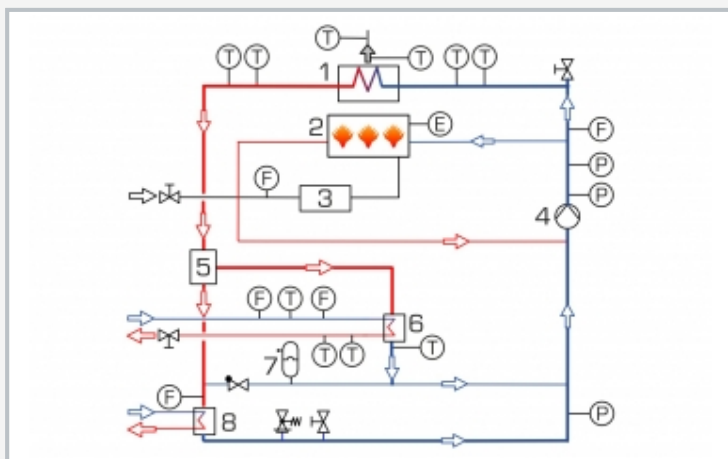

Process schematic: 1 heat exchanger, 2 burner, 3 compact fitting, 4 pump, 5 three-way valve, 6 heat exchanger as hot water consumer, 7 expansion vessel, 8 plate heat exchanger as radiator

### Specification

- [1] familiarisation with a typical combination boiler
- [2] main components clearly mounted on panel
- [3] burner with viewing window for observation of flame
- [4] plate heat exchanger simulates radiator, cold water used as heating load
- [5] additional instrumentation for energy balances: thermometers, flow meters, manometers
- [6] operation with propane gas

### Technical data

#### Gas boiler

- nominal heating capacity range: 8.9...18kW
- standard utilisation rate at nominal load: 93%
- feed flow temperature: 82...87°C
- hot water temperature: 30...65°C
- permissible excess operating pressure
  - ▶ heater: 3bar
  - ▶ hot water: 10bar
- exhaust gas temperature: 90...125°C

#### Expansion vessel

- capacity: 2L
- admission pressure: 1,5bar

230V, 50Hz, 1 phase  
 LxWxH: 1650x700x1900mm  
 Weight: approx. 115kg

### Required for operation

propane gas: 1,72kg/h, 50mbar  
 water connection, drain  
 ventilation, exhaust gas routing

### Scope of delivery

- 1 trainer
- 1 manual