

HM 166

Fundamentals of sediment transport

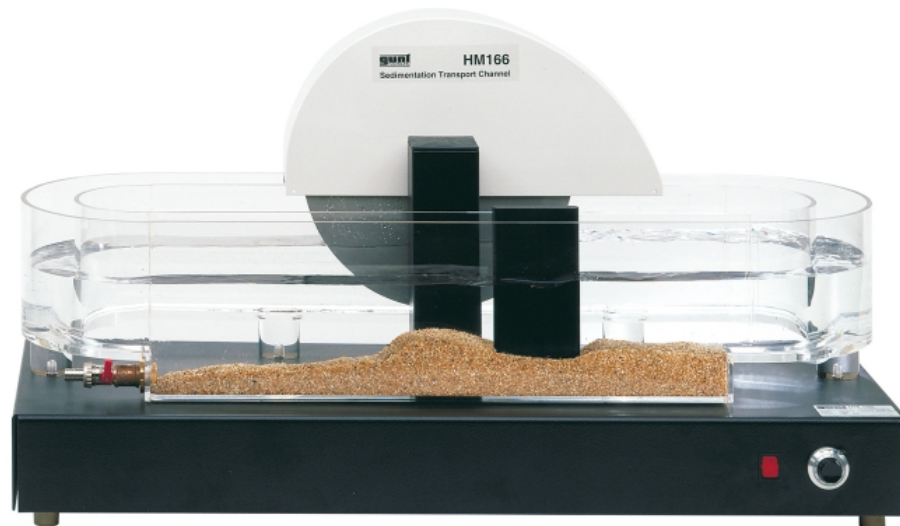

Description

- sediment transport in open channels
- circulating flow channel with transparent side walls as open channel
- observing ripple formation and fluvial obstacle marks

In many real open channels there is sediment transport that affects the flow behaviour. Normally the key component is bed-load transport. HM 166 uses sand to demonstrate important phenomena of bed-load transport in the area near the bottom. The transparent experimental section allows observation of the formation of ripples in the river bed.

HM 166 consists of a circulating, oval, transparent flow channel. A deepening for holding the sediment in the longitudinal side of the channel forms the experimental section. The other longitudinal side contains a paddle wheel that produces the flow. A flow straightener at the inlet to the experimental section ensures low-turbulence flow.

The speed of the paddle can be adjusted in order to study how the flow velocity affects the bed-load transport. Flow velocities can be generated in the region of critical discharge (without sediment). The paddle is driven by an electric motor and a belt drive. Motor and speed adjustment are located under the base plate and are water resistant.

The fluvial obstacle mark, i.e. scour formation and siltation at bridge piers, is observed at three different pier models, which are inserted into the experimental section.

Learning objectives/experiments

- observation of
 - ▶ starting conditions for bed-load transport
 - ▶ how flow velocity affects bed-load transport
 - ▶ ripple and dune formation on the river bed
 - ▶ fluvial obstacle mark of bridge piers (scour formation and siltation)
 - ▶ secondary flows in channel bends
- additionally with fine sand
 - ▶ observation of solid matter flows
 - ▶ how sediment size and density affect sediment transport

HM 166

Fundamentals of sediment transport

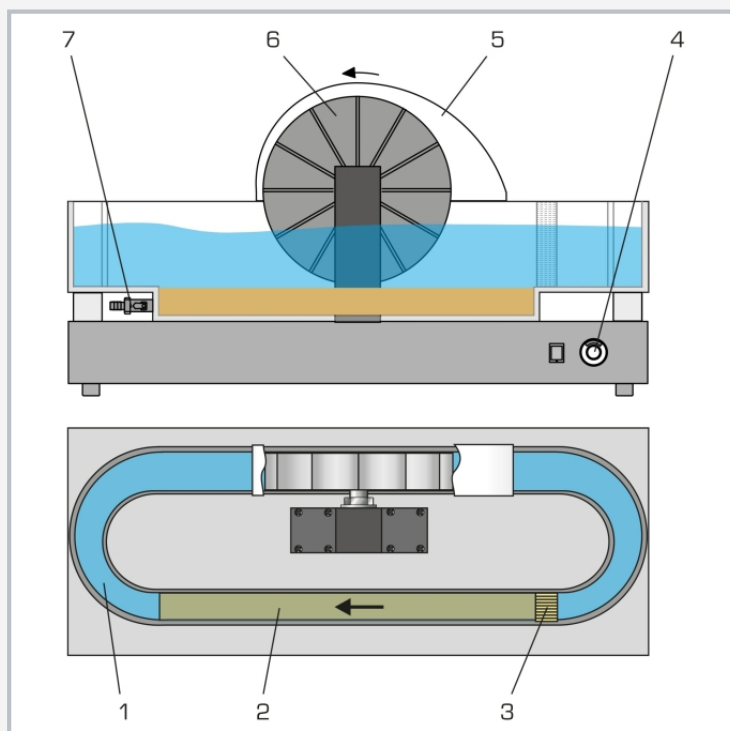

1 flow channel, 2 experimental section, 3 flow straightener, 4 paddle speed adjustment, 5 splash guard, 6 paddle, 7 drainage valve

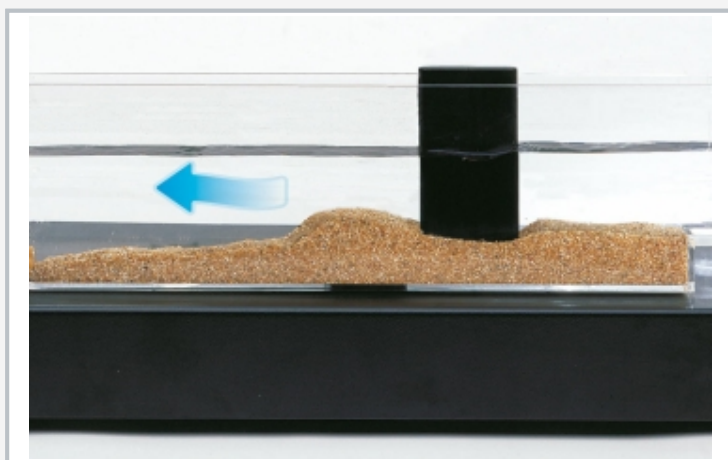

Fluvial obstacle mark (scour formation and siltation) on piers

Specification

- [1] experimental unit for bed-load transport in open channels
- [2] transparent, circular, oval flow channel as open channel
- [3] variable-speed paddle to generate the flow velocity
- [4] experimental section with transparent deepening for holding the sediment
- [5] low-turbulence flow at the inlet to the experimental section thanks to a flow straightener
- [6] paddle driven via electric motor and belt drive
- [7] three different bridge piers for observing fluvial obstacle marks on piers

Technical data

Experimental section

- length: 660mm
- cross-section WxH: 50x200mm
- deepening: 50mm

Flow channel

- height: 150mm
- width: 50...72mm

Paddle

- 12 blades
- Ø 330mm
- speed at the paddle: 5,2...70min⁻¹

Measuring ranges

- flow velocity: approx. 0...1m/s

230V, 50Hz, 1 phase

230V, 60Hz, 1 phase; 120V, 60Hz, 1 phase

UL/CSA optional

LxWxH: 1030x410x560mm

Weight: approx. 42kg

Scope of delivery

- 1 experimental unit
- 3 piers
- 1 sand (5kg, 1...2mm grain size)
- 1 set of accessories
- 1 set of instructional material

HM 166

Fundamentals of sediment transport

Optional accessories

WP 300.09 Laboratory trolley