

# HM 240

## Principles of air flow

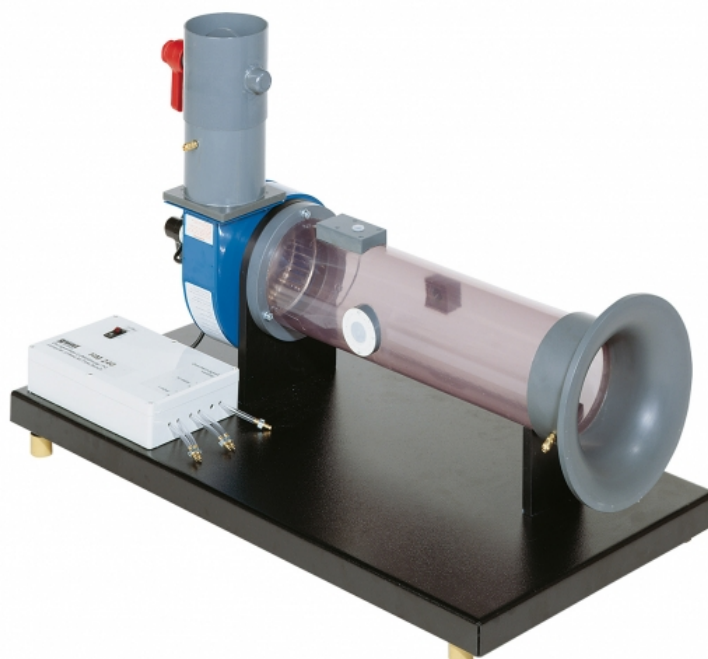

### Description

- wide range of accessories for basic experiments with air flow
- record a fan characteristic

HM 240 is part of a series that allows experiments on the fundamentals of air flow. The software for data acquisition and visualisation makes the experiments especially clear and enables fast execution of experiments with reliable results.

The experimental unit includes a radial fan, which can be used to generate flow velocities up to 9m/s. An inlet contour on the intake side ensures a low-turbulence flow and thus a homogeneous velocity distribution in the measuring section. A throttle valve on the end of the pressure pipe can be used to adjust the air flow to allow the fan characteristic curve to be recorded. When used in conjunction with the power meter HM 240.02 it is possible to determine the efficiency of the fan.

Further accessories for additional experiments can be attached in the intake pipe: electronic total pressure sensor HM 240.03, pressure distribution on a cylinder HM 240.04 and heat transfer at a cylinder in transverse flow HM 240.06. To study the friction losses, the intake pipe is replaced with pipe elements from HM 240.05 (straight pipes, pipe bends and pipe angles).

Measuring points along the measuring section allow temperature, pressure and velocity measurements to be taken. The flow rate is determined by means of the inlet contour and the pressure measurement. The measured values are transmitted directly to a PC via USB. The data acquisition software is included.

### Learning objectives/experiments

- recording a fan characteristic
- in conjunction with the power meter HM 240.02
  - ▶ determining the fan efficiency
- in conjunction with corresponding accessories
  - ▶ velocity distribution in the pipe
  - ▶ velocity distribution behind a cylinder subject to transverse incident flow
  - ▶ pressure distribution around a cylinder subject to transverse incident flow
  - ▶ friction losses in pipes, pipe bends and pipe angles
  - ▶ recording the cooling curve of a copper cylinder subject to incident flow
  - ▶ determining the heat transfer coefficients from the cooling curve

# HM 240

## Principles of air flow

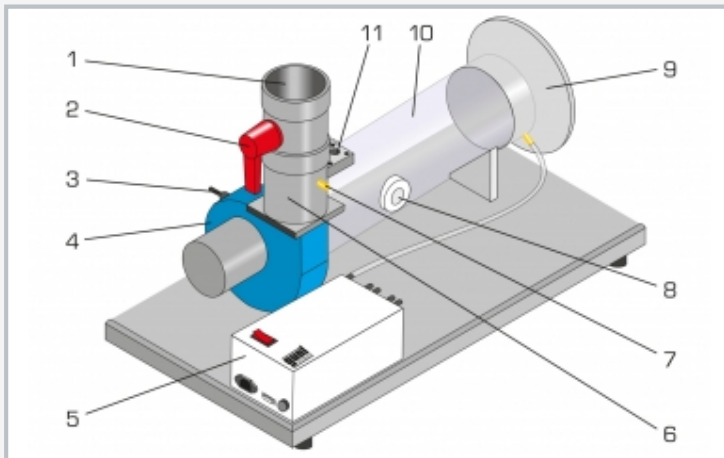

1 air outlet, 2 throttle valve for adjusting the air flow, 3 measuring point for temperature, 4 fan, 5 switch box with pressure transducer, 6 delivery pipe, 7 measuring point for pressure, 8 connector for accessory HM 240.04 / HM 240.06, 9 air inlet, 10 intake pipe, 11 connector for Pitot tube HM 240.03

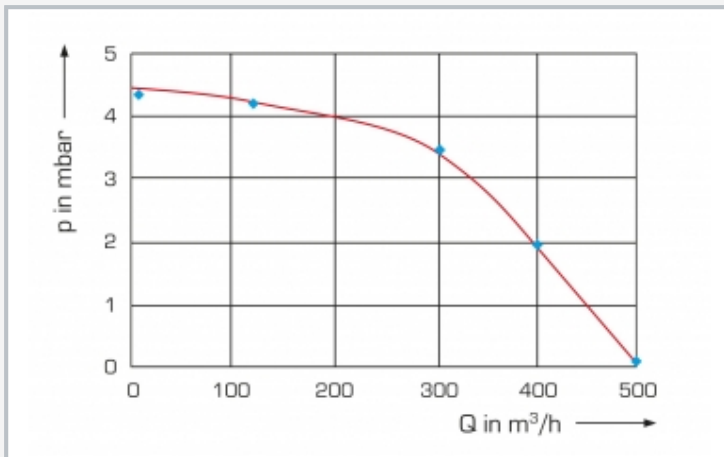

Representation of a fan characteristic  
blue: measured values, red fan characteristic; p pressure, Q volumetric flow rate

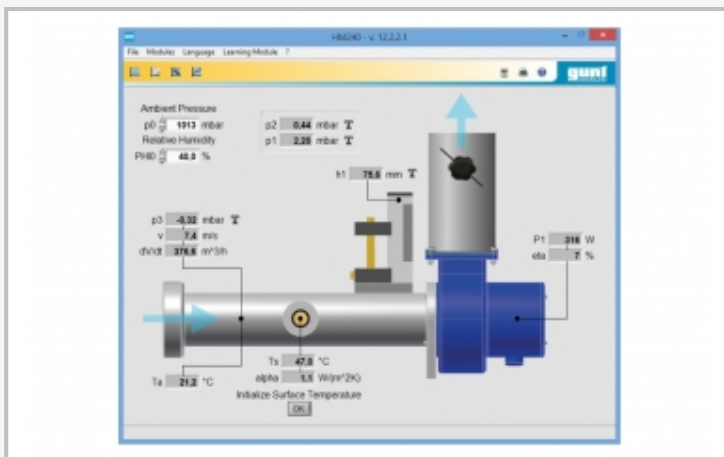

Screenshot of the software together with the electronic total pressure sensor accessory HM 240.03 and pressure distribution on a cylinder HM 240.04

### Specification

- [1] investigation of the principles of air flow
- [2] transparent intake pipe with mounting options for additional accessories
- [3] inlet contour minimises turbulence on the intake side
- [4] throttle valve on the delivery pipe to adjust the air flow
- [5] electronic measurement of temperature and pressure
- [6] determine velocity by means of the dynamic pressure
- [7] determine flow rate via differential pressure
- [8] GUNT software for data acquisition via USB under Windows 8.1, 10

### Technical data

#### Radial fan

- max. power consumption: 90W
- speed: 2800min<sup>-1</sup>
- max. flow rate: 460m<sup>3</sup>/h
- max. differential pressure: 480Pa

#### Delivery pipe

- outer Ø: 110mm
- inner Ø: 99,4mm

#### Intake pipe

- outer Ø: 140mm
- inner Ø: 134,4mm

#### Measuring ranges

- pressure: 1x ±10mbar
- pressure: 2x ±1mbar
- temperature: 0...200°C

230V, 50Hz, 1 phase

230V, 60Hz, 1 phase; 120V, 60Hz, 1 phase

UL/CSA optional

LxWxH: 850x450x600mm

Weight: approx. 23kg

### Required for operation

PC with Windows

### Scope of delivery

- 1 experimental unit
- 1 set of hoses
- 1 GUNT software + USB cable
- 1 set of instructional material

# HM 240

## Principles of air flow

### Optional accessories

070.24002	HM 240.02	Power meter
070.24003	HM 240.03	Electronic total pressure sensor
070.24004	HM 240.04	Pressure distribution on a cylinder
070.24005	HM 240.05	Pressure losses in pipe elements
070.24006	HM 240.06	Heat transfer at a cylinder in transverse flow
020.30009	WP 300.09	Laboratory trolley