

HM 365.10

Supply unit for water pumps



Learning objectives/experiments

- in combination with HM 365 and a pump of the series HM 365.11 – HM 365.19
 - ▶ recording of pump characteristics
 - ▶ determination of the power requirement of the pump
 - ▶ determination of the hydraulic power of the pump
 - ▶ determination of the pump efficiency
 - ▶ determination of the system characteristics and the pump's operating point
 - ▶ checking of the required NPSH value of the rotodynamic pumps

Description

- closed water circuit to supply the water pumps
- GUNT Software for data recording and visualisation
- part of the GUNT FEMLine

Pumps belong to the group of driven machines. Their task is to transport incompressible fluids. Pumps are categorised into rotodynamic pumps and positive displacement pumps, depending on their principle of operation.

Rotodynamic pumps transfer energy to the fluid with the help of blades arranged on an impeller. The blades are shaped in a way that the flow around them causes a pressure difference between the inlet and outlet side.

Positive displacement pumps move the pumping medium by changing the volume and by opening and closing inlets and outlets correspondingly. Depending on the design of the displacement device the volume changes through oscillating or rotating movements. Rotodynamic pumps, such as centrifugal pumps, are of advantage where large flow rates are required, while positive displacement pumps, such as piston pumps, are better suited for smaller flow rates with a high head.

The supply unit HM 365.10 supplies the working medium water for several centrifugal pumps and positive displacement pumps (HM 365.11 to HM 365.19). The pumps are powered in conjunction with the HM 365 Universal Drive and Brake Unit.

The trainer works independently of the water supply network, using a closed circuit with a storage tank. The individual pumps are placed on the work surface and connected by means of hoses with quick-release couplings, and attached with clamping levers. The pump is connected to the drive unit, which provides it with power via a V-belt.

The flow rate is measured with an electromagnetic flow rate sensor. A temperature sensor records the temperature in the piping system. Each pump is equipped with pressure sensors for measuring the pressure. The measured values are read from digital displays on the supply unit and can be transmitted simultaneously via USB directly to a PC, where they can be analysed using the included software.

HM 365.10

Supply unit for water pumps

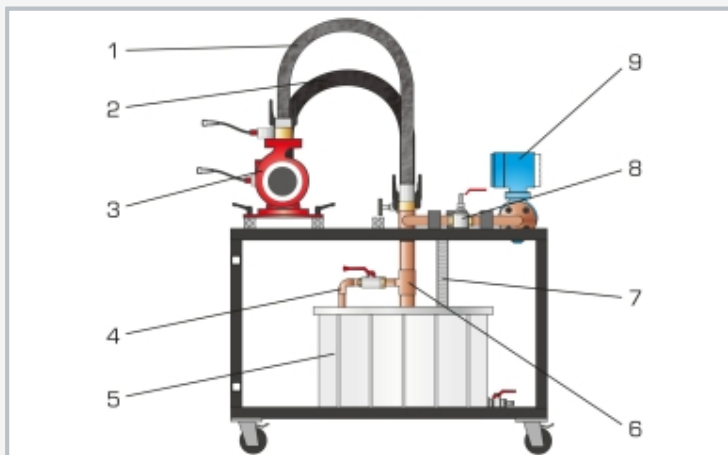

1 outlet, 2 inlet, 3 accessories: pump [HM 365.11 – HM 365.19], 4 drain line, 5 storage tank, 6 intake pipe, 7 reflux, 8 flow control valve, 9 flow meter

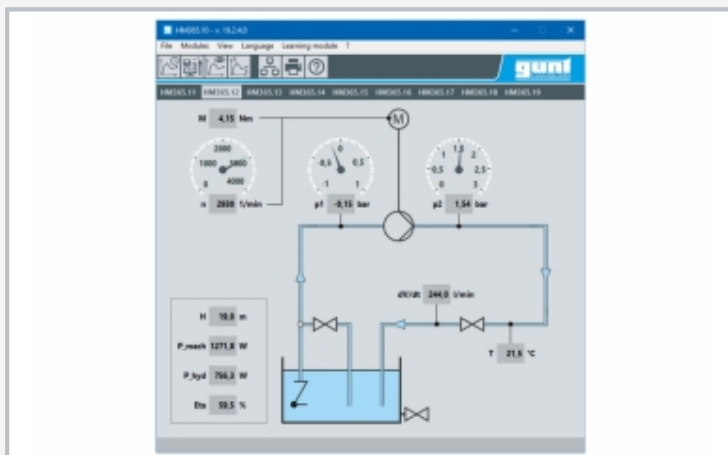

Software screenshot: process schematic



Functional experimental setup: HM 365 drive unit (left), HM 365.10 with pump to be examined (right)

Specification

- [1] supply unit for operation of different water pumps HM 365.11 to HM 365.19
- [2] closed water circuit
- [3] connection of pumps via flexible hoses with quick-release couplings
- [4] pressure sensors at the inlet and outlet included in the scope of delivery of the pumps
- [5] measurement of the water temperature in the pipeline system with PT100
- [6] flow measurement with electromagnetic flow meter
- [7] digital display of flow, pressure and temperature
- [8] GUNT software for data acquisition via USB under Windows 10

Technical data

Storage tank: 96L

Measuring ranges

- pressure (inlet): ± 1 bar
- pressure (outlet): 0...6bar
- temperature: 0...100°C
- flow rate: 0...480L/min

230V, 50Hz, 1 phase
 230V, 60Hz, 1 phase
 120V, 60Hz, 1 phase
 UL/CSA optional
 LxWxH: 1200x850x1150mm
 Weight: approx. 140kg

Required for operation

PC with Windows recommended

Scope of delivery

- 1 supply unit
- 1 display and control unit
- 1 set of hoses
- 1 GUNT software + USB cable
- 1 set of instructional material

HM 365.10

Supply unit for water pumps

Required accessories

HM 365 Universal drive and brake unit

Optional accessories

Rotodynamic pumps

HM 365.11 Centrifugal pump, standard design
HM 365.12 Centrifugal pump, self-priming
HM 365.13 Centrifugal pump, multistage
HM 365.14 Centrifugal pumps, series and parallel connected

Side channel pump

HM 365.15 Side channel pump

Positive displacement pumps

HM 365.16 Lobe pump
HM 365.17 Reciprocating piston pump
HM 365.18 Gear pump
HM 365.19 Vane pump

for Remote Learning

GU 100 Web Access Box
with
HM 36510W Web Access Software