

HM 500

Flow meter trainer



Description

- **comparison and calibration of different flow meters**
- **plotting of pressure loss curves**
- **numerous flow meters available as accessories**

Flow measurement plays a key role in many process engineering systems. Different flow meters are used for this, depending on the medium and application.

The HM 500 trainer is used to examine different principles of operation of flow meters. The flow meters are available as accessories (HM 500.01-HM 500.16). Pressure loss curves and accuracies can be compared to determine which flow meter is suitable for which area of application.

One horizontally or vertically installed flow meter can be operated in a closed water circuit. The flow rate can be adjusted via a valve. A high-precision electromagnetic flow rate sensor is available as a reference for calibrating the flow meters.

To be able to determine the pressure losses of the various flow meters, the trainer is equipped with two twin tube manometers and a differential pressure sensor. A DC voltage source ensures the power supply to the flow meters if required.

Learning objectives/experiments

- together with different flow meters available as accessories
 - ▶ different flow meters and their principles of operation
 - ▶ calibration of different flow meters
 - ▶ position dependency of flow meters
 - ▶ plotting and comparison of pressure loss curves

HM 500

Flow meter trainer

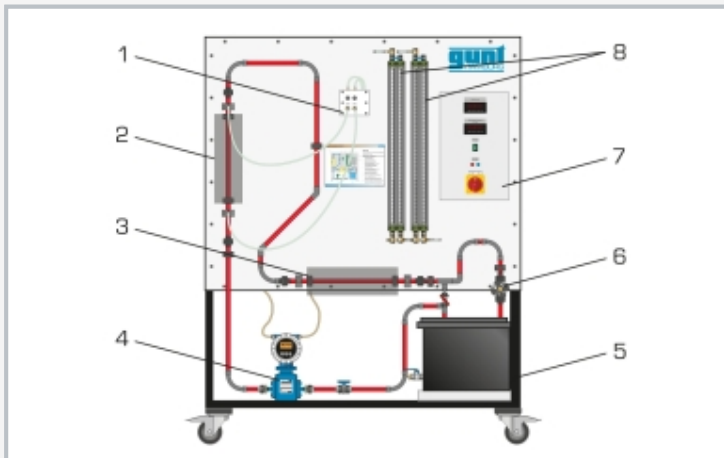

1 differential pressure sensor, 2 vertical measuring location with HM 500.10, 3 horizontal measuring location with empty tube, 4 electromagnetic flow rate sensor, 5 tank with pump, 6 valve to adjust flow rate, 7 switch cabinet, 8 twin tube manometers

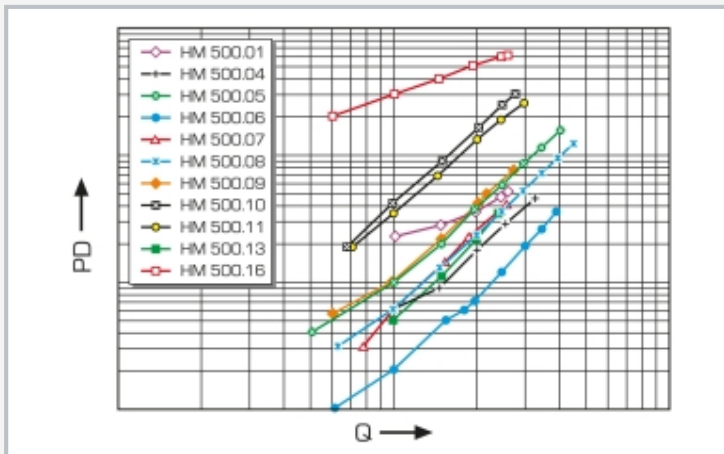

Pressure loss (PD) dependent on the flow rate (Q) for the flow meters available as accessories

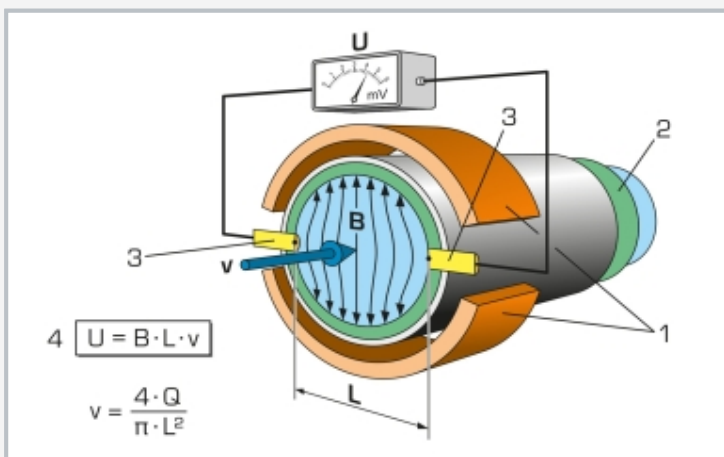

Measurement principle of the electromagnetic flow rate sensor:
1 magnet, 2 insulation, 3 electrode, 4 Faraday's Law of Induction; B magnetic flux density, L electrode gap, Q flow rate, U induced voltage, v flow velocity of medium (blue)

Specification

- [1] comparison and calibration of different flow meters
- [2] water circuit with tank, pump and valve to adjust flow rate
- [3] 2 measuring locations for vertical or horizontal installation of the flow meters under test
- [4] electromagnetic flow rate sensor for reference measurement
- [5] 1 differential pressure sensor and twin tube manometers for measurement of pressure losses
- [6] DC voltage source to supply the flow meters with auxiliary power
- [7] flow meters available as accessories

Technical data

Tank: approx. 55L

Pump

- max. flow rate: 150L/min
- max. head: 7,6m

DC voltage source

- voltage: 24VDC
- current: 2,0A

Accuracy of electromagnetic flow rate sensor

- 0,5% of final value

Measuring ranges

- flow rate: 0...4760L/h (reference)
- differential pressure: 0...1000mbar
- pressure: 0...680mmWC (twin tube manometers)

230V, 50Hz, 1 phase

230V, 60Hz, 1 phase; 120V, 60Hz, 1 phase

UL/CSA optional

LxWxH: 1770x670x1880mm

Weight: approx. 110kg

Scope of delivery

- 1 trainer
- 1 set of hoses
- 1 set of cables
- 1 set of accessories
- 1 set of instructional material

HM 500

Flow meter trainer

Optional accessories

HM 500.01	Rotameter
HM 500.03	Rotameter with transducer
HM 500.04	Electromagnetic flow meter
HM 500.05	Ultrasonic flow meter
HM 500.06	Venturi nozzle
HM 500.07	Pitot tube
HM 500.08	Orifice plate flow meter
HM 500.09	Measuring nozzle
HM 500.10	Paddle wheel flow meter
HM 500.11	Vortex flow meter
HM 500.13	Orifice plate flow meter with transducer
HM 500.14	Turbine wheel flow meter
HM 500.15	Bypass flow meter
HM 500.16	Baffle plate flow meter