

## BASIC KNOWLEDGE

## POSITIVE DISPLACEMENT PUMPS

## Fundamental principles of positive displacement pumps

In positive displacement pumps the energy is transferred to the fluid hydrostatically. In the hydrostatic transfer of energy a displacement body reduces a working chamber filled with fluid and pumps the fluid into the pipe. In this case, the displacement body applies a pressure to the fluid. When the working chamber expands it is refilled with fluid from the pipe.

The work done  $W_s$  results from the product of the displacement force  $F$  and displacement distance  $s$ . This equation can also be written as the product of displaced volume  $V_s$  and delivery pressure  $p$ .

$$W_s = F \cdot s = A \cdot p \cdot s = V_s \cdot p$$

The power transferred to the fluid is calculated from the flow rate  $Q$  and delivery pressure  $p$ .

$$P = Q \cdot p$$

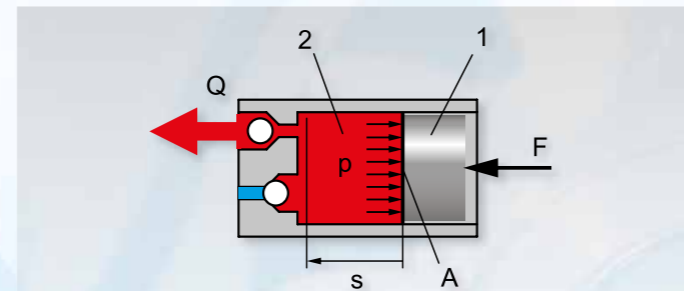

1 displacement body, 2 working chamber; Q flow rate, F displacing force, A area, p delivery pressure, s displacement distance

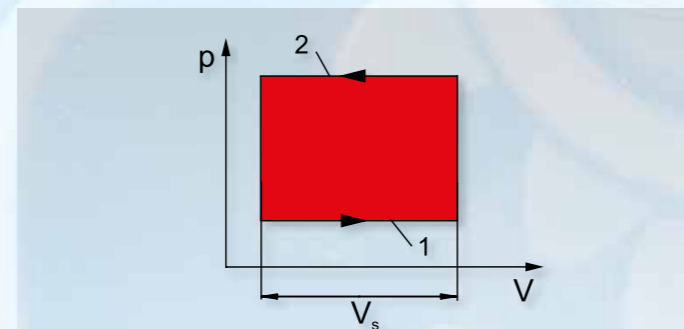

Representation of the pump process of a positive-displacement pump in the  $p, V$  diagram. During suction 1 the volume increases at low pressure. Pushing out 2 occurs as the volume reduces at high pressure. The enclosed area corresponds to the work done on the fluid.

## Advantages of positive displacement pumps

- flow rate only slightly dependent on the head; thus well suited for dosing and injection pumps
- suitable for high pressures; only one stage required
- very good suction capacity, even with gas content
- suitable for high viscosity (pastes)
- flow rate can be adjusted very precisely and reproducibly via stroke and stroke rate
- cyclical delivery possible
- well suited for low drive speeds
- direct pneumatic, hydraulic or electromagnetic drive possible with oscillating pumps

## Disadvantages of positive displacement pumps

- principle of operation does not include a pressure restriction, therefore safety or pressure relief valves are necessary
- in oscillating positive displacement pumps vibration-free operation is only possible with complex mass balancing
- oscillating positive displacement pumps less suitable for high speeds
- in oscillating positive displacement pumps, pulsating flow is necessary, as is a pulsation dampener
- in some more complicated designs, fault-prone construction with valves
- larger number of wear parts than centrifugal pumps

## Types of positive displacement pump

In positive displacement pumps a distinction is made between **oscillating** and **rotary** pumps.

## EXAMPLES OF OSCILLATING POSITIVE DISPLACEMENT PUMPS

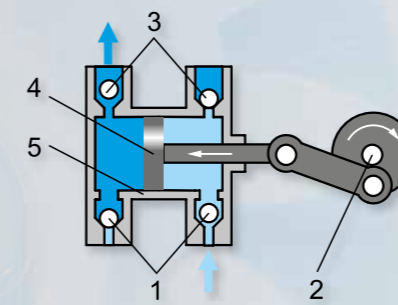

Piston pump

## Structure of oscillating positive displacement pumps

- 1 suction valve,
- 2 crank mechanism,
- 3 pressure valve,
- 4 piston,
- 5 cylinder,
- 6 diaphragm,
- 7 eccentric mechanism

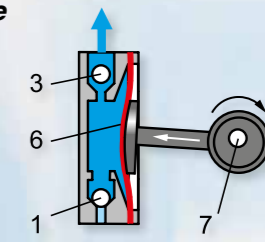

Diaphragm pump

## EXAMPLES OF ROTARY POSITIVE DISPLACEMENT PUMPS

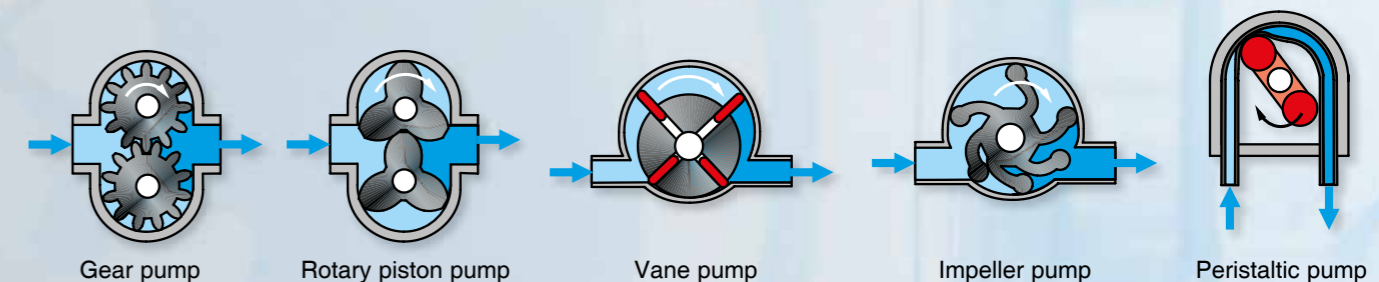

Since rotary positive displacement pumps usually have large working chambers that are filled and emptied in overlap, these pumps deliver more evenly than oscillating positive displacement pumps with only smaller working chambers. The rotating displacement bodies mean the pumps have good mass balancing and low vibrations even when running at higher speeds.

For applications where a pulsed delivery is desired, such as in fuel injection pumps for engines, only oscillating positive displacement pumps are suitable. Oscillating positive displacement pumps generally have a more complicated design because the rotating drive must be converted into an oscillating stroke movement. This is done via a crank, eccentric or cam mechanism. In addition, at least one pressure control valve is necessary to prevent backflow of the fluid.

## Operating behaviour and operating points of a positive displacement pump

Positive displacement pumps have very steep characteristics. The flow rate  $Q$  is almost independent of the head  $H$ . The maximum head  $H_{max}$  is usually limited by a pressure relief valve or safety valve. Therefore, the flow rate is almost independent of the system characteristic. In contrast to centrifugal pumps, the flow rate cannot be regulated by increasing the system resistance. This is realised by a change in the rotational speed ( $n_1-n_3$ ) or the displaced volume. The black curves represent the system characteristics at different speeds 1...3.

